

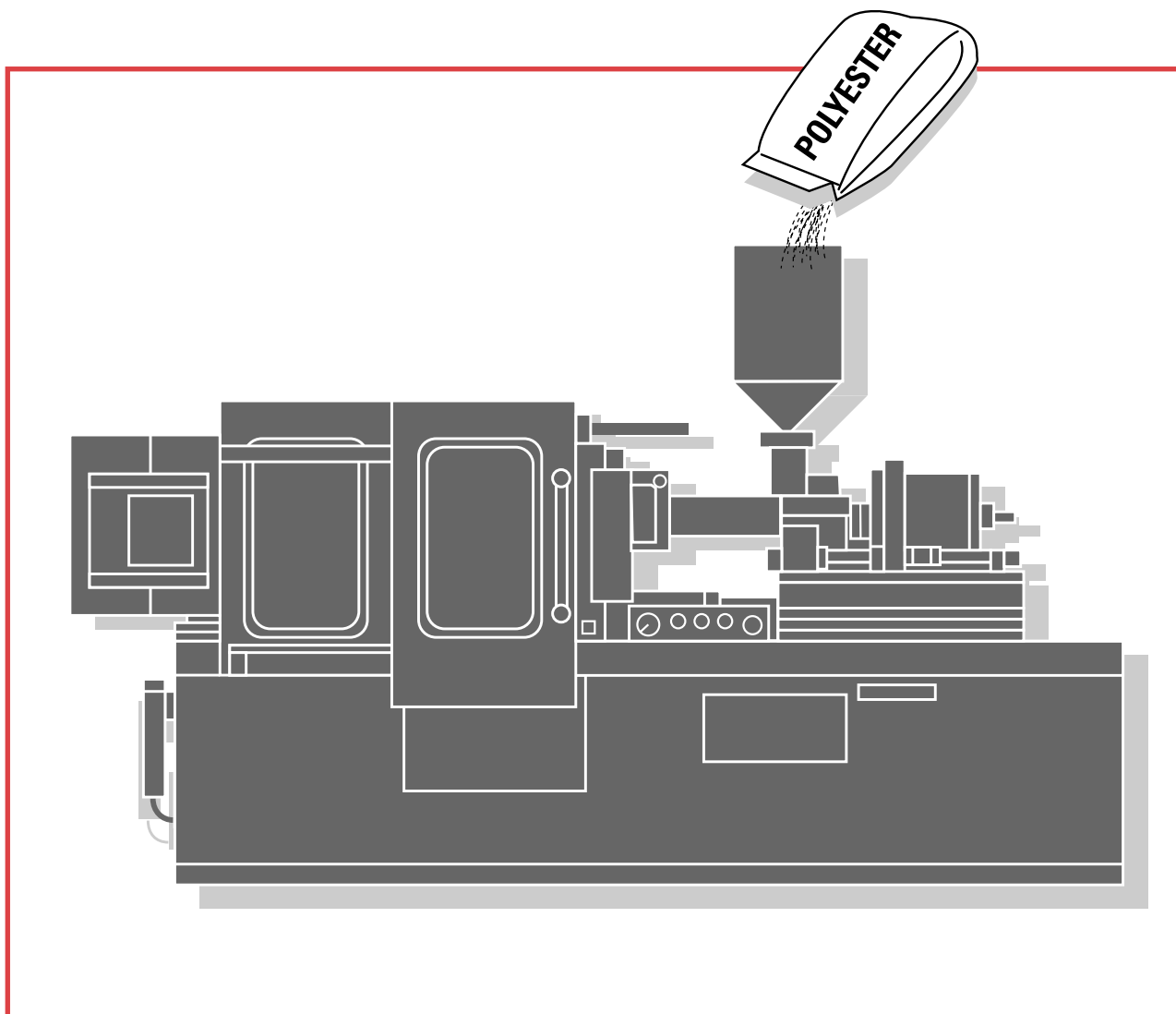

Crastin® PBT and Rynite® PET

Thermoplastic Polyester Resins

Moulding Manual



Start
with DuPont
Engineering Polymers

Moulding manual for CRASTIN® PBT and RYNITE® PET

Table of contents

1 General information	3	4 Mould	13
1.1 Foreword	3	4.1 Mould temperature control	13
1.2 Description	3	4.2 Mechanical structure	14
1.3 Safety precautions	3	4.3 Runner system and gate layout	14
1.4 Handling and preparation of materials	4	4.4 Hot runner	15
1.4.1 Packaging	4	4.5 Venting	16
1.4.2 Storage	4	4.6 Draft angles	16
1.5 Environment and disposal of waste	4	4.7 Sharp corners	16
2 Drying principles	5	5 Material behaviour	19
2.1 Effects of moisture	5	5.1 Chemical structure	19
2.2 Moisture absorption	5	5.2 Flow length	19
2.3 Drying conditions	6	5.3 Shrinkage	21
2.4 Drying equipment	6	5.4 Post-shrinkage	22
3 Moulding	7	6 Auxiliary operations	23
3.1 Process	7	6.1 Regrind	23
3.1.1 Injection unit	7	6.2 Colouring	23
3.1.1.1 Screw	7		
3.1.1.2 Back flow valve	7		
3.1.1.3 Corrosion/abrasion	7		
3.1.1.4 Nozzles	7		
3.1.1.5 Accumulator for thin wall applications	8		
3.1.2 Start-up and shutdown procedures	8		
3.1.2.1 Purging	8		
3.1.2.2 Start-up	8		
3.1.2.3 Shutdown	9		
3.1.2.4 Interruptions	9		
3.2 Parameters	9		
3.2.1 Melt and cylinder temperature	9		
3.2.2 Cavity temperature	10		
3.2.3 Injection phase	10		
3.2.4 Hold pressure phase	11		
3.2.5 Screw retraction phase	11		
3.2.6 Processing recommendation table	11		

We recommend that you refer to the injection moulding recommendations for CRASTIN® and RYNITE® on pages 35 and 36.

1 General information

1.1 Foreword

CRASTIN® and RYNITE® glass reinforced thermoplastic polyester resins are unique among polyester systems. These products contain uniformly dispersed glass fibres and/or other fillers, specially formulated for rapid crystallisation during the injection moulding process. This makes possible the production of high performance parts by conventional injection moulding techniques.

In this brochure, general handling and processing techniques are discussed.

1.2 Description

RYNITE® thermoplastic polyester resins contain uniformly dispersed glass fibres or mineral/glass combinations in polyethylene terephthalate (PET) resin which has been specially formulated for rapid crystallisation during the moulding process. RYNITE® thermoplastic polyester resins have an outstanding combination of properties – high strength, stiffness, excellent dimensional stability, outstanding chemical and heat resistance and good electrical properties.

RYNITE® resins are noted for their excellent melt flow characteristics, close moulding tolerances and high productivity from multicavity moulding. The properties, processing characteristics and competitive price of RYNITE® resins lead to high value-in-use and lower part costs. CRASTIN® PBT thermoplastic resins are based on polybutylene terephthalate (PBT) resin, which have been specially formulated for rapid crystallisation during moulding process and may contain uniformly dispersed glass fibres or glass beads.

As with RYNITE®, the CRASTIN® resins have an outstanding combination of properties, so that they can fulfil the demands of various applications.

The melting points of PBT resins is about 30 K lower than that of PET resins, resulting in lower melt temperatures during moulding as well as slightly lower allowable design temperatures for moulded parts.

Please refer to the RYNITE® and CRASTIN® Product and properties guide for more detailed product descriptions and their properties.

1.3 Safety precautions

While processing CRASTIN® and RYNITE® resins is ordinarily a safe operation, consideration should be given to the following:

A. Since CRASTIN® and RYNITE® resins are moulded at high temperatures, the molten resin can inflict severe burns. Furthermore, above the melting point, moisture and other gases may generate pressure in the cylinder which, if suddenly released, can cause the molten polymer to be violently ejected through the nozzle.

To minimize the chance of an accident, the instructions given in this manual should be followed carefully. Potential hazards must be anticipated and either eliminated or guarded against by following established procedures including the use of proper protective equipment and clothing.

Be particularly alert during purging and whenever the resin is held in the machine at higher than usual temperatures or for longer than usual periods of time – as in a cycle interruption. Pay particular attention to the section on moulding conditions.

In purging, be sure that the high volume (booster) pump is off and that a purge shield is in place. Reduce the injection pressure and “jog” the injection forward button a few times to minimize the possibility that trapped gas in the cylinder will cause “splattering” of the resin.

Put the purged resin immediately into a metal container with cold water to limit the evolution of smell and gasing.

If there is any suspicion that gases are being formed in the cylinder, move the purge shield in place, back the nozzle away from the mould, turn off all heat except to nozzle and the nozzle adapter, and leave the machine until it cools below the melting point of the resin (225°C for CRASTIN®, 245°C for RYNITE®). Then, with purge shield still in place reheat the cylinder to the minimum or screw temperature. If jogging the injection or screw rotation buttons do not produce melt flow, a plug exists. In that case, shut off cylinder heat as before and follow your established safety practices for removing the nozzle. A face shield and protective long sleeve gloves should be used.

In the event that molten polymer does contact the skin, cool the affected area immediately with cold water or an ice pack and get medical attention for thermal burn. Do not attempt to peel the polymer from the skin.

B. Since CRASTIN® and RYNITE® resins are dried at high temperature, contact with hot hoppers, ovens or air hose lines could result in severe burns. Insulation of these components will reduce this possibility.

- C. Small amounts of gases and particulate matter (i.e. low molecular weight modifiers) may be released during the moulding, purging or drying of CRASTIN® or RYNITE®. We recommend that adequate local exhaust ventilation be provided during the processing of CRASTIN® or RYNITE®. We have calculated that a ventilation rate of 5 m³ of air per minute per kg of resin processed per hour will keep the concentration of dust particles below 10 mg/m³ while being processed at the maximum recommended times and temperatures (moulding, purging and drying).
- D. CRASTIN® and RYNITE®, like all thermoplastic polymers, can form gaseous decomposition products during long hold-up times at the maximum recommended melt temperatures.
- E. Adequate local exhaust ventilation should also be provided during the regrind operation.
- F. Prior to cleaning of any barrel that contains CRASTIN® or RYNITE® resins, the machine should be thoroughly purged with polyethylene or polystyrene.
- G. If CRASTIN® and RYNITE® resin is accidentally purged over the heater bands, it should be removed and not allow to degrade.
- H. Adequate local exhaust ventilation must be provided during the burnout of any equipment that contains CRASTIN® or RYNITE® resin, e.g. nozzles, etc.
- I. Granules of CRASTIN® or RYNITE® present a slipping hazard if spilled on the floor. They are cube shaped and have a low coefficient of friction. They should be swept up immediately.
- J. Avoid to mould/purge with polycarbonate (PC) before or after RYNITE®. Use some intermediate purging steps as described in chapter 3.1.2.
- K. For any further information please refer to the Safety Data Sheets.

1.4 Handling and preparation of materials

1.4.1 Packaging

The precautions for handling CRASTIN® and RYNITE® resins are generally the same as those for similar glass-reinforced hygroscopic materials, e.g. polyesters, polycarbonates. CRASTIN® and RYNITE® resins are packaged in moisture-proofed bags, but the moisture content of the resins in this special moisture-proof bag can be higher than the maximum allowed moisture level for moulding.

Broken bags should be well closed or best sealed in order to prevent excessive moisture pick-up over time.

Full details of packaging types are given in the brochures: “Introduction to Engineering Polymers Packaging Materials” (H-51358) and “Silo Shipment” (H-38473).

1.4.2 Storage

Both CRASTIN® and RYNITE® resins should be stored dry and storage should allow a “first in/first out” inventory policy. Even though the bags are protected against moisture by a special lamination, some pickup could occur over time.

1.5 Environment and disposal of waste

RYNITE® PET is based on the same polymer which is largely used for soft drink bottles with respect to its good environmental behaviour.

The good melt stability of CRASTIN® and RYNITE® allows in general the recycling of properly handled production waste. If recycling is not possible, DuPont recommends, as the preferred option, incineration with energy recovery. The incinerator has to be equipped with a state of the art scrubber in order to clean the flue gases before release.

CRASTIN® and RYNITE® are not soluble in water and have practically no additives which can be extracted by water. Therefore CRASTIN® and RYNITE® represent no known risk to human health or the environment when land filled.

For any disposal, local regulations have to be observed which can vary significantly from locality to locality.

Polyethylene terephthalate and polybutylene terephthalate are mentioned on the ‘green list’ of the European Regulation EEC 259/93, Annex II. Thus, CRASTIN® and RYNITE® are not restricted for inter European transport of waste destined for recovery.

2 Drying principles

2.1 Effects of moisture

CRASTIN® and RYNITE® are very critical where the moisture is concerned and must always be dried to ensure that optimum mechanical properties are obtained.

The symptoms of moulding resin with excessive moisture are shown in Table 2.1 and Figures 2.1-2.2.

Table 2.1 How to recognize excess moisture content

Polymer	Influence on mechanical properties	Visible symptoms on moulded parts	Symptoms when moulding
CRASTIN®	Reduction in impact and tensile strength	Surface streaks (splaying) are visible	• No significant symptoms
RYNITE®	Drastic reduction in impact and tensile strength		• More flash formation

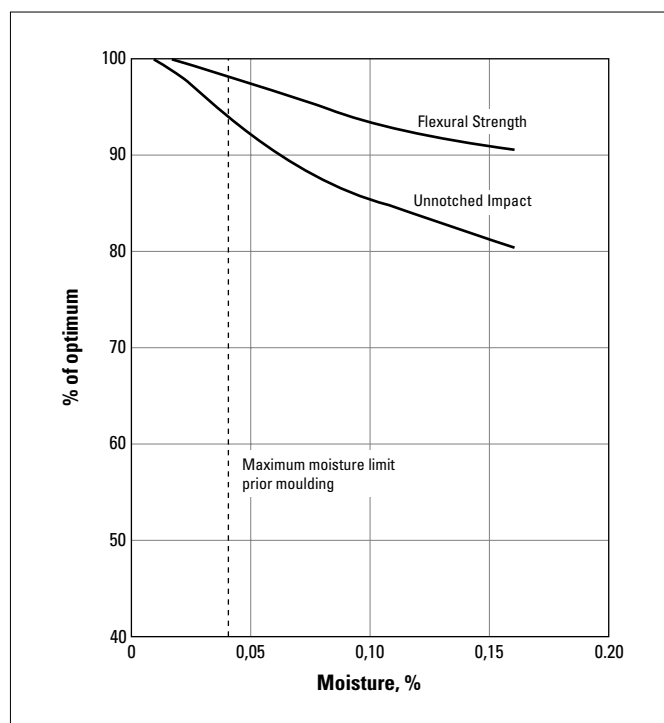

Fig. 2.1 Effect of resin moisture level on properties of CRASTIN® SK605

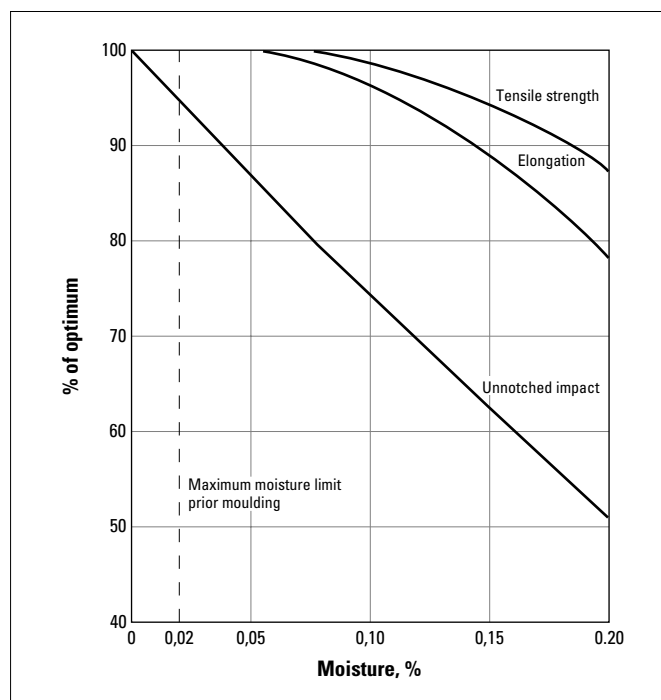

Fig. 2.2 Effect of resin moisture level on properties of RYNITE® 530

2.2 Moisture absorption

CRASTIN® and RYNITE® have different behaviours in terms of moisture absorption.

Well dried CRASTIN® PBT will reach the maximum recommended moisture level for processing within approximately 2 hours at ambient conditions of 23°C and 50% RH, whereas RYNITE® PET will reach this state already within 10 minutes at 23°C and 50% RH. (See Figure 2.3 and Table 2.2).

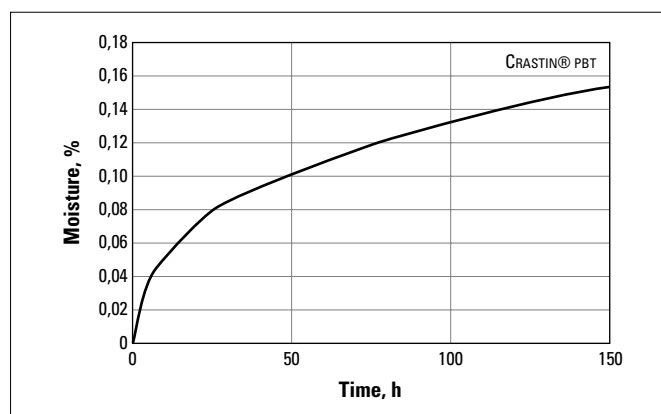

Fig. 2.3 Moisture pick up of CRASTIN® S600F10

Table 2.2 Time required for RYNITE® to reach 0,02% moisture

Granules initial moisture	Exposure time in minutes at 23°C		
	20% RH	50% RH	90% RH
0,005%	235	30	8
0,010%	110	13	4
0,015%	27	3	1

2.3 Drying conditions

Moisture in the granules results in an hydrolytic reduction of the molecular weight during processing which causes a reduction in strength and toughness of moulded parts.

CRASTIN® and RYNITE® PET need always pre-drying to obtain the best properties for moulded parts.

Table 2.3 summarizes the drying recommendations. Further details are in the processing recommendations table at pages 35-36.

Table 2.3 Recommended drying conditions

	Maximum allowed moisture for processing (%)	Drying temper. (°C)	Drying time (h)
CRASTIN®	0,04	120	3-4
RYNITE®	0,02	130	3-4

Too low drying temperatures, i.e. 80°C as used for polyamides, result in insufficient drying, which means that the required moisture limit can not be reached. This fact is important when using central drying systems, that do not allow individual temperature setting of the drying containers.

2.4 Drying equipment

a. Desiccant driers

Pre-drying with desiccant driers is the most reliable and economical drying method. Monitoring and controlling of desiccant driers takes place by

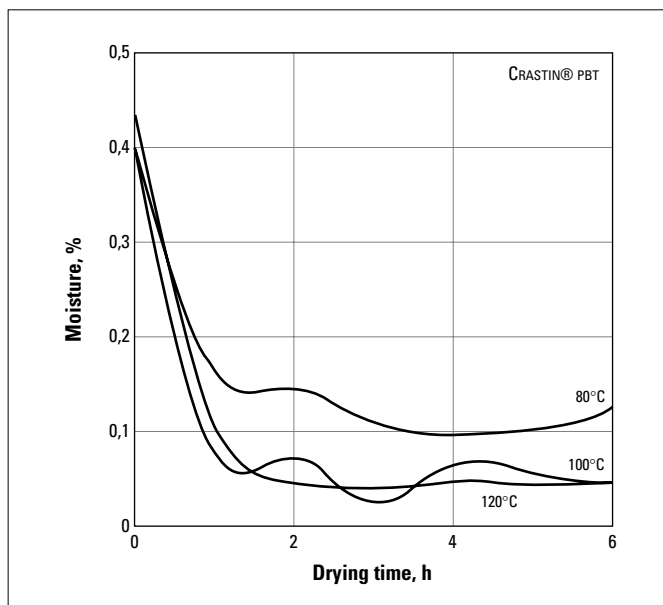

Fig. 2.4 CRASTIN® PBT never reaches 0,04% moisture when dried at 80°C

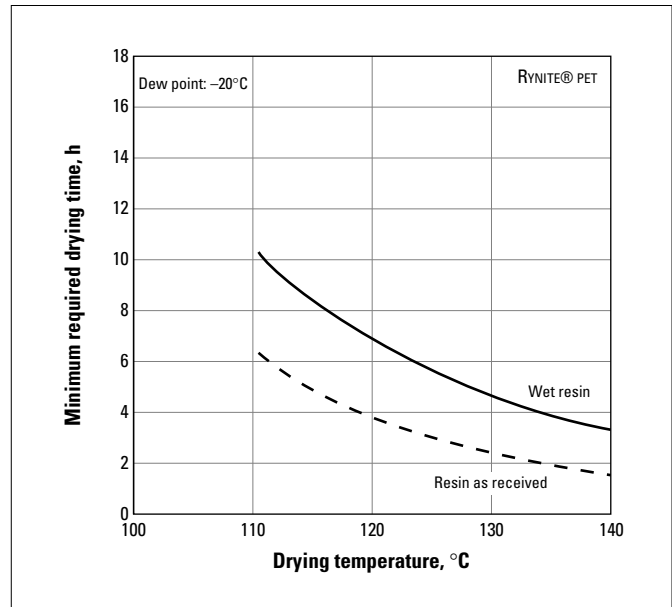

Fig. 2.5 Drying time vs. air temperature to obtain 0,02% moisture for RYNITE®

determination of the dew point. The dew point indicates directly the proportion of water in the air. Values of -20°C and below for the dew point make for efficient drying. Drying with desiccant driers is independent of atmospheric influences.

b. Circulating air oven

The quality of the drying depends on the atmospheric conditions. High humidity of the air reduces the acceptable level of drying. Therefore we can not recommend the use of such driers.

c. Vacuum driers

Vacuum driers are for economical reasons normally used only in laboratories. In vacuum, heat energy is transferred almost exclusively by radiation. This results in a long heating time. The recommended drying time is therefore 50% longer than the recommended drying time in Table 2.3.

d. Degassing

The use of degassing units on injection moulding machines is, with the current state of the art, not a fully equivalent alternative to pre-drying. The main reason for this is the CRASTIN® and RYNITE® hydrolytical degradations of the polymer melt until it reaches the vent port.

e. Conveying systems

Taking into account the relative short moisture absorption time of polyester (especially RYNITE® PET) it is recommended to use dried air in the conveying system. The dried resin should not stay longer than 10 minutes in the hopper under normal atmospheric conditions.

3 Moulding

3.1 Process

3.1.1 Injection unit

3.1.1.1 Screw

CRASTIN® and RYNITE® can be processed on all commercially available screw injection moulding machines.

In order to obtain good homogenization and to ensure careful processing, the L/D ratio of the screws used should not be too small (min. 20D). Standard three-zone screws with shut-off rings, such as those commonly used for polyamides, can be used for CRASTIN® and RYNITE®.

3.1.1.2 Back flow valve

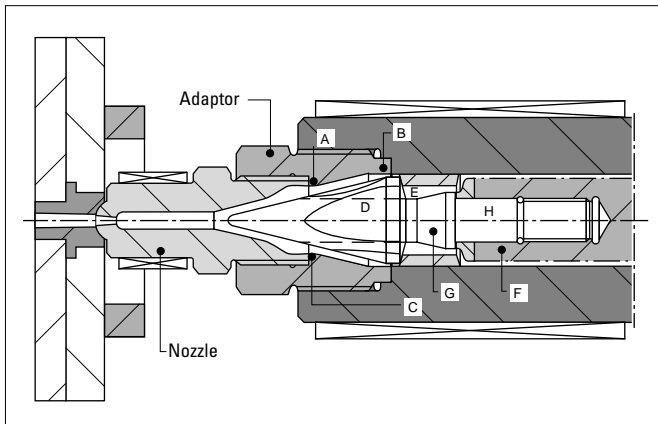

Fig. 3.1 Design of adaptor and back flow valve

The back flow valve or check ring shown in Fig. 3.1 prevents melt from flowing backward during injection. It may happen that this unit is not properly designed to eliminate holdup of resin and flow restrictions. Malfunctioning that allows resin backflow is also a common experience and is caused by poor design or maintenance. A leaking non-return valve will add to screw retraction time, which can increase cycle, and it will also cause poor control of packing and dimensional tolerances.

The non-return valve must meet the following requirements:

- No holdup spots.
- No flow restrictions.
- Good seal.
- Control of wear.

These requirements are provided for in the back flow valve shown in Fig. 3.1.

The slots or flutes (D) in the screw tip are generously proportioned, and the space (E) between the check ring and tip is sufficient for resin flow.

The seating of the fixed ring is cylindrical where it joins both the end of the screw (F) and the screw tip (G) to permit accurate matching of these diameters and avoid holdup.

The screw tip thread has a cylindrical section (H) ahead of the threads that fits closely in a matching counterbore for support and alignment of the screw tip and seat ring.

The screw tip and check ring seat should be harder (about Rc 52) than the floating ring (Rc 44), because it is less expensive to replace the floating ring when wear occurs.

Wear resistant steel is suggested for the tip. Good matching of cylindrical diameters is essential to avoid holdup spots.

3.1.1.3 Corrosion/abrasion

CRASTIN® and RYNITE® resins, like other glass-reinforced resins, can cause wear in certain areas of the barrel, screw and mould. When moulding large quantities of these resins, certain precautions should be taken to minimize wear effects in the equipment and moulds. To improve the injection unit when processing glass-reinforced resins such as CRASTIN® and RYNITE®, hard surfacing alloys and/or high loaded steels should be used for barrels, screws and back flow valves. Tests on bi-metallic specially treated injection units (barrel, screw and back flow valve) show a lifetime improvement of 5 to 10 times compared to standard equipment. In order to minimize screw wear, special abrasion and corrosion resistant steels and treatments are available.

Please contact your machine and screw manufacturer for further details and recommendations. Specific corrosion resistance treatments of the injection unit is normally not required for moulding.

3.1.1.4 Nozzles

CRASTIN® and RYNITE® can be processed with open nozzles. However, decompression of the melt must be carried out after the end of plasticising.

Long, unheated nozzles are unsuitable, as the melt can freeze very rapidly if the tip of the nozzle touches the cold tool. If extended machine nozzles are used, good temperature control must be maintained over the whole nozzle length in order to prevent overheating.

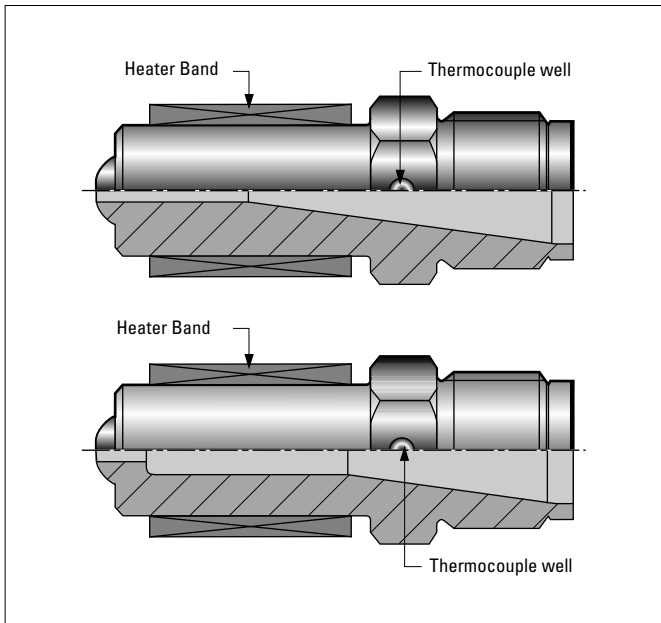

Fig. 3.2 Recommended open nozzles

Self-closing nozzles, particularly those with complicated flow channels, should not be used. With certain needle-type self-closing nozzles, problems due to wear and blocking of the needle can occur when glass fibre reinforced materials are processed.

If self-closing nozzles are used for processing CRASTIN® containing glass fibres, the cylinder and nozzle should be purged with an unreinforced material (e.g. PE) before shutting down the machine. This prevents glass fibres from being deposited when the machine is reheated.

Except in the case of hot runner tools, the nozzle should be withdrawn from the tool after completion of the metering operation. If the nozzle remains in contact with the tool it cools rapidly and consequently the temperature of the nozzle must be increased to prevent freezing. This, in turn, leads to thermal degradation of the melt. Nozzle diameters should not be too small, again in order to prevent premature freezing.

The nozzle should always be equipped with an independent temperature controller. A simple power control is often too inaccurate to guarantee precise temperature regulation.

3.1.1.5 Accumulator for thin wall applications

CRASTIN® and RYNITE® glass-reinforced grades generally require fast injection speed. Machines equipped with an accumulator may help to increase flow length especially in applications with thin walls.

3.1.2 Start-up and shutdown procedures

3.1.2.1 Purging

Purging is essential before and after moulding RYNITE® resins because many other plastics degrade at the RYNITE® melt processing temperature. Contamination of RYNITE® with other resins such as nylon, polycarbonate, acetal, polybutylene terephthalate (PBT), or polyarylate may cause moulding difficulty and/or resin decomposition.

The best purging materials are polystyrene, cast acrylic (the nozzle must be removed during purging) and high density polyethylene (or glass-reinforced polyethylene), followed by high density polyethylene). The following purge procedure is recommended for standard injection moulding equipment:

- A. Retract screw injection unit from sprue bushing and keep the screw in the forward position.
- B. Run the screw at high RPM and pump out as much of the material as possible. Add and extrude purge compound until it comes out clean. Cylinder temperatures may have to be adjusted, depending on purge material used.
- C. It is good practice to “shoot” several air shots at a fast injection rate to scrub walls of cylinder before switching to another resin. Care should be employed to avoid possible splatter of molten resin when this is done.

The following purge procedure is recommended for hot runner systems:

- A. Shield personnel from mould.
- B. Raise manifold temperatures 30° C above first resin’s melt temperature or 10° C above desired RYNITE® melt temperature (but less than 310° C actual), whichever is lower.
- C. Extrude dried RYNITE® through open mould using machine back pressure, until purge is “clear”.
- D. Drop manifold temperature to operating conditions. Purge out “hot” RYNITE® (1 to 2 minutes maximum).
- E. Drop pressures to usual lower RYNITE® levels.

3.1.2.2 Start-up

- A. Start with a clean machine and a closed feed hopper slot.
- B. Set the cylinder temperature to 30° C below the minimum moulding temperature and the nozzle at the operating temperature. Allow heat to “soak in” for at least 20 minutes. Raise cylinder temperature to the operating levels.

- C. Check to see if the nozzle is at the right temperature.
- D. Jog screw. If the screw will not rotate, allow a longer soak time for cylinder temperature.
- E. When the screw begins to rotate, open feed slot briefly and then close it. Check the torque on the screw drive. If it is excessive, increase rear zone temperature. The nozzle must be open at this time.
- F. Open the feed slide and keep the screw in forward position. Start screw rotation and increase the front zone temperature if unmelted particles are seen.
- G. Adjust the stroke to the approximate shot weight and run a few minutes at the approximate overall cycle. The melt temperature should now be checked with a needle probe pyrometer. Make any adjustments in the cylinder temperatures necessary to obtain the recommended melt temperature. (This procedure should be repeated when a significant cycle change occurs.)
- H. Bring injection cylinder forward. Start at a low injection pressure (except where short shots will interfere with part ejection) and adjust the moulding variables for the best part appearance and maximum part weight.

3.1.2.3 Shutdown

The machine should be purged thoroughly (see 3.1.2.1 “Purging”) which cuts the time required for subsequent start-up and reduces problems of contamination. The following shutdown procedure is suggested:

- A. Shut hopper feed slide, while continuing to mould on cycle.
- B. Empty hopper, add a quantity of polystyrene or polyethylene, extrude until the screw pumps itself dry.
- C. Leave screw in forward position.
- D. Shut down power supply.

3.1.2.4 Interruptions

If short moulding interruptions occur which exceed 2 minutes, it is essential that the cylinder be purged with fresh granulate. Failure to purge after such interruptions to the moulding cycle will lead to defective parts being produced due to thermal degradation of the material. The actual number of unacceptable parts will depend upon the shot weight.

These measures are also necessary when processing CRASTIN® and RYNITE® on hot runner moulds. Particularly with small shot weights, the hot runner must also be purged with fresh granulate after a cycle interruption. If the moulding interruption duration exceeds 15 minutes, it is recommended to empty the cylinder and to lower the cylinder temperature to 215°C for CRASTIN® and 245°C for RYNITE® in order to avoid excessive thermal degradation.

3.2 Parameters

3.2.1 Melt and cylinder temperature

The melt temperature is taken directly from the molten polymer (using a needle pyrometer) and should be checked periodically during a moulding run to ensure that it does not exceed the recommended limits.

Figure 3.3 shows the relationship between shot weight, cycle time and melt temperatures for CRASTIN®. In order to take into account the sensitivity of the melt to overheating, processing temperatures must be matched to hold up times. The longer the residence time of the melt in the cylinder, because of low shot weight or long cycle times (e.g. due to insert placing), the lower should be the cylinder temperatures. When selecting the machine or the screw diameter, care should be taken that the resulting shot weight is not too low.

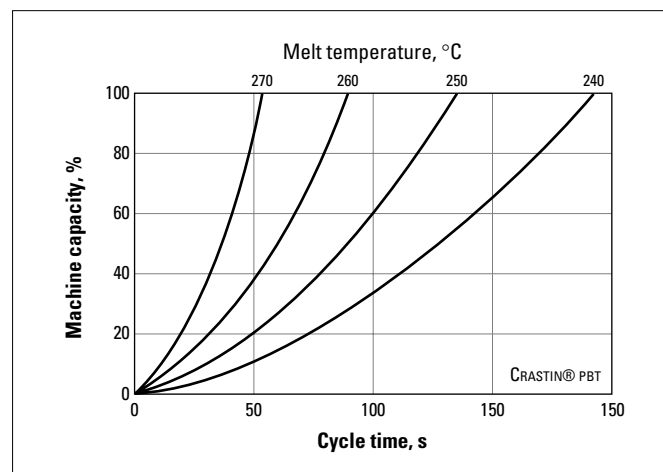

Fig. 3.3 Permissible cycle times for CRASTIN® as a function of shot weights at various melt temperatures

Figure 3.4 displays the maximum permissible residence time of RYNITE® PET versus melt temperature.



Fig. 3.4 Processing range:
PET melt temperature vs. residence time

Generally for moulding semi-crystalline polymers like CRASTIN® PBT and RYNITE® PET, the cylinder temperature profile should be relatively flat. Figure 3.5 proposes temperature profiles as function of residence time and per cent of stroke. It should be avoided to set any cylinder temperature zone below the melting point of polymer.

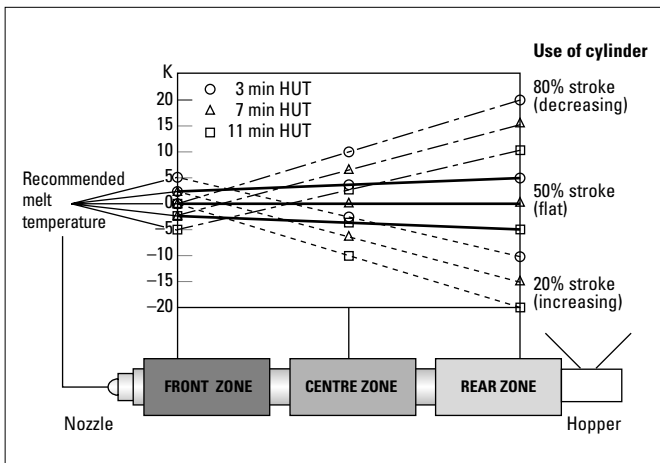

Fig. 3.5 Cylinder temperature profile for a constant melt temperature

For more detailed information please refer to processing recommendation table.

3.2.2 Cavity temperature

In order to produce moulded CRASTIN® and RYNITE® parts with optimum characteristics and low post-shrinkage, a sufficient degree of crystallization of the polymer must be achieved. This is influenced to a great degree by the mould temperature.

For CRASTIN® processing can be carried out with mould temperatures in the range of 30-130°C. Mould temperature should be increased as the wall thickness of moulded parts is reduced.

Generally, a mould temperature of approximately 80°C is sufficient to obtain parts with low post-shrinkage. For precision parts which will be subject to high temperature in service a mould temperature of over 100°C may be necessary, particularly with unreinforced CRASTIN®. High mould temperatures reduce the risk of dimensional changes caused by post-crystallization (post-shrinkage).

For some CRASTIN® types, a minimum mould temperature of 80°C must be observed.

As for RYNITE® a mould surface temperature of 110°C is suggested for optimum properties, dimensional stability and surface appearance of moulded parts. For thicker parts, due to insulating properties of plastics, a mould temperature of 90°C will still result in good properties and dimensional stability. High mould temperatures yield a better surface with higher gloss. When mould temperatures between 60°C and 85°C are used, the initial warpage and shrinkage will be lower, but the surface appearance may be poorer and the dimensional change of the part will be greater when the part is heated above 85°C. If a minimum as-moulded warpage is the only requirement, RYNITE® resins can be processed with mould surface temperatures of less than 60°C.

3.2.3 Injection phase

Glass-reinforced CRASTIN® and RYNITE® grades generally require medium to fast injection speeds.

The optimum filling time is dependant on part design, wall thickness, flow length, shot volume, gate and runner design. Therefore, no more specific recommendations can be given in this guide. It is important to provide adequate venting to avoid burn marks.

The injection pressure during the dynamic mould filling phase is a function of:

- the programmed injection speed;
- material viscosity at its melt temperature;
- material crystallisation speed;
- cavity flow resistance (geometry, wall thickness, flow length).

The resulting injection pressure may be much lower than hold pressure, i.e. for thick parts and short flow length, or even much higher than hold pressure, i.e. for thin parts and long flow length.

3.2.4 Hold pressure phase

The recommended specific hold pressure levels are:

- for CRASTIN® 60 MPa
- for RYNITE® 80 MPa

As for any other semi-crystalline polymer the hold pressure level should be constant over the hold pressure time.

The correct hold pressure time is easy to determine on the injection moulding machine. Several different hold times are set, 0,5 to 1,0 s a part, depending on the required resolution, and the resultant mouldings weighed on a laboratory balance after removing the runner and sprue. The optimum hold pressure time will be in the region where there is no longer any change in the weight of moulded parts. This presupposes that the gate has been correctly positioned and designed.

Table 3.1 helps to roughly estimate the required hold pressure time for a given wall thickness.

Table 3.1 Crystallisation rate for a wall thickness of 3 mm

Material	Crystallisation time per mm wall thickness
PET GF30	3,0-4,0 s/mm
PBT	3,5-4,5 s/mm
PBT GF30	2,5-3,5 s/mm

In order to optimize the cycle time, the cooling time is usually set just above the plasticising time.

3.2.5 Screw retraction phase

Even though CRASTIN® and RYNITE® grades are not specifically sensitive to high shear, it is recommended to respect the maximum rotational speed as in Figure 3.6.

This will limit screw abrasion for glass reinforced grades and will avoid excessive heat through shear.

No or low back pressure should be used. The effect of back pressure is to produce additional screw working which can cause fibre breakage with reduction in physical properties of the moulded part. Increasing

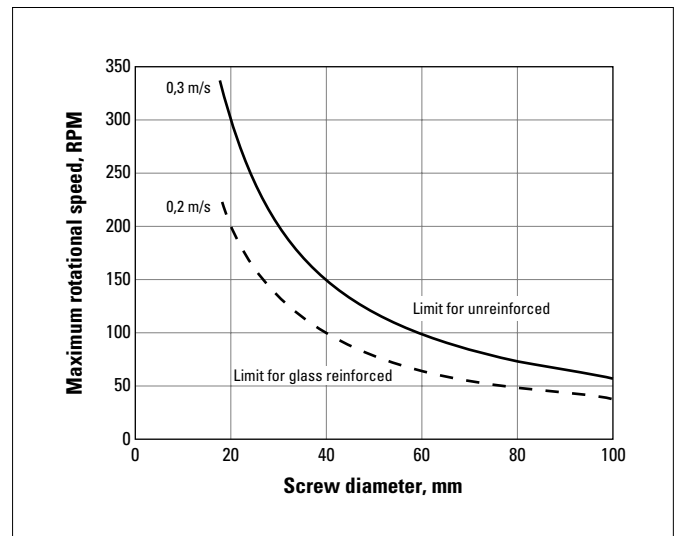

Fig. 3.6 Screw speed vs. screw diameter

back pressure increases the work done by the screw on the molten polymer. This could incrementally increase melt temperature and uniformity. Where melt quality is marginal, higher back pressure may reduce unmelted particles, but it will not substantially increase melt quality.

Increasing back pressure also increases recovery time. The lowest possible back pressure consistent with good melt quality is recommended during the moulding of DuPont polyester resins.

Normally only melt decompression, is required in order to avoid leakage of material from the nozzle. The use of decompression helps to prevent nozzle drool from hot-runner tools and to stop vent discharge in vented cylinders.

Use of excessive decompression can cause air to be sucked in through the nozzle. This can result in oxidation of material which will be seen as areas of discoloration in the moulding. Another consequence could also be the injection of a cold slug in the next shot leading to surface defect and to part weakness.

3.2.6 Processing recommendation table

The injection moulding recommendations on pages 35-36 contain specific information about drying conditions, melt temperature, mould temperature and ISO shrinkage.

4 Mould

4.1 Mould temperature control

Mould temperature control must be a part of the overall design concept for the mould. As already mentioned mechanical properties, cycle time, dimensional accuracy and distortion of the part are influenced by mould temperature.

In order to achieve a consistent cavity surface temperature, it is essential to have a well designed regulation circuit in the mould beside the temperature controller with suitable pressure, heating and cooling capacity.

Basic recommendations:

- When moulding CRASTIN® and RYNITE® mould surface temperature is much higher than room temperature. In order to shorten the time needed to heat the mould and to maintain constant temperature, insulating plates should be provided between mould and machine.
- For large moulds and temperatures above 100°C, it is recommended to thermally insulate the mould on its outside walls.
- Flat mould areas should be adapted with spiral- or drilled cooling channels. Recommended diameters and their approx. distance from the surface of the mould are shown in the table of Fig. 4.1. Depending on the size of the part it may be necessary to provide several separate cooling circuits. The temperature difference between entering and exiting fluid should be as small as possible (<5°C).

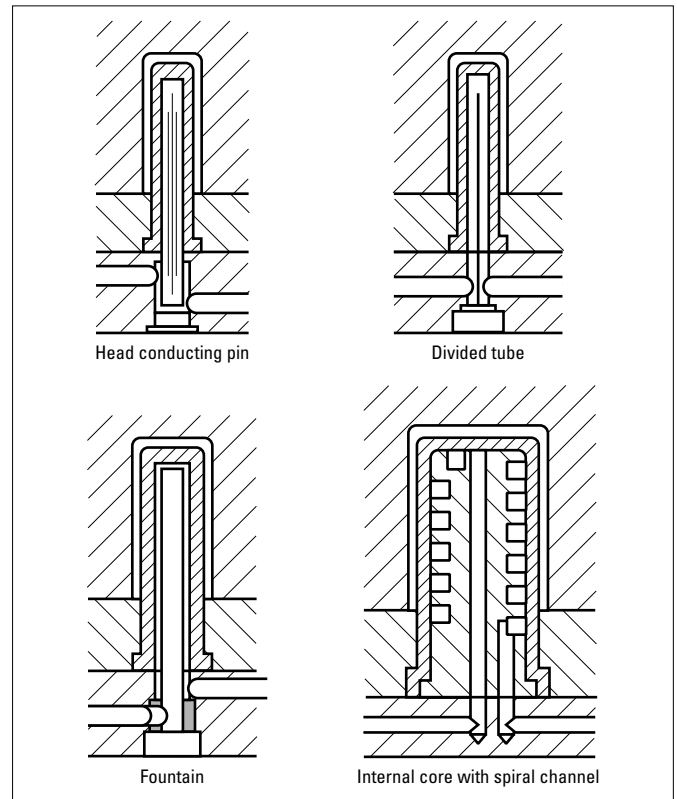
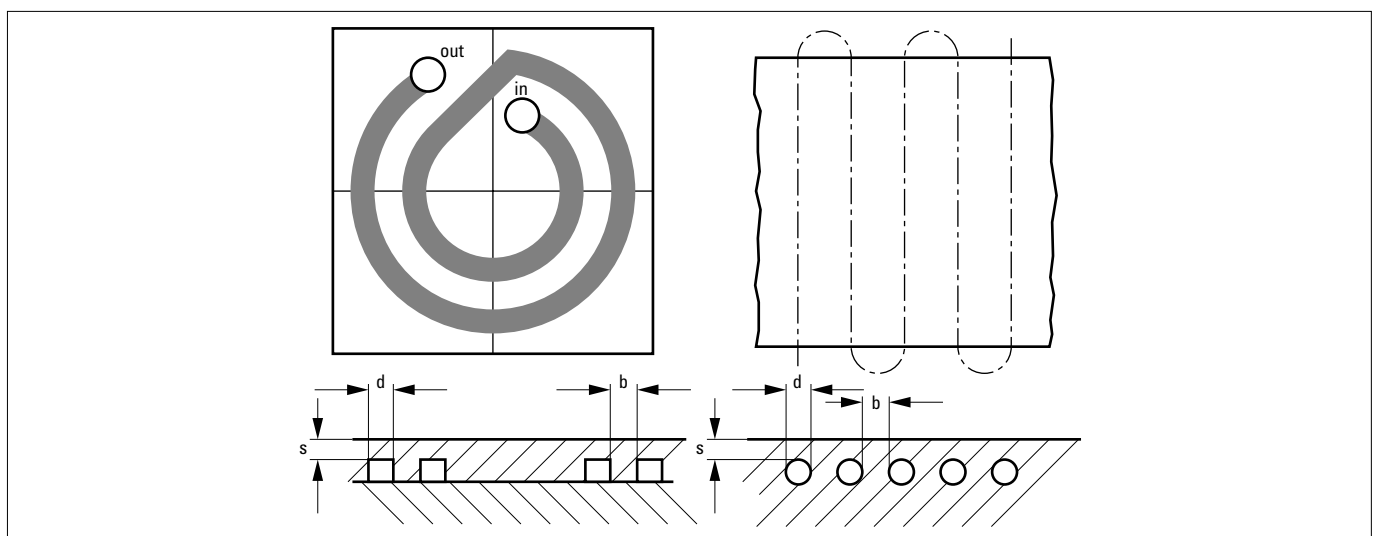

Fig. 4.2 Possible methods of cooling cores

- A separate or serial cooling circuit is recommended for multi-cavity tools, because the flow rate can easily be controlled. A parallel configuration may lead to different surface temperature as choking over time causes different flow rates in the parallel channels.



Wall thickness of the moulding	Channel diameter or width (d)	Distance (s)	Channel spacing (b)
up to 2 mm	8 mm	4 mm	~ 1 d
up to 4 mm	10 mm	7 mm	~ 1 d
up to 6 mm	12 mm	9 mm	~ 1 d

Fig. 4.1 Mould temperature control for flat parts

- It is important to have an efficient core cooling in order to obtain possible shortest cycle time. Figure 4.1 shows some constructions of cooling cores.
- Temperature control should also be provided in slides and pulling cores.

4.2 Mechanical structure

CRASTIN® and RYNITE® require medium to fast injection speeds. Especially in thin wall applications the specific injection pressure may exceed 100 MPa. Therefore a stiff mould construction will have an important contribution to:

- flash free moulding;
- longer mould lifetime;
- larger processing window (i.e. faster injection speed).

Recommendations for increasing mould stiffness:

- use thick platens;
- use large spacer blocks;
- use very stable frame when using many inserts or large hot runner systems;
- use support blocks between rear clamping plate and support plate.

4.3 Runner system and gate layout

In designing the feed system, the first point to be considered is the wall thickness (t) of the moulded part (see diagram). Nowhere should the diameter of the runner be less than the wall thickness of the injection moulding. Starting out from the gate, the runner diameter at each branch point can be widened so that an almost constant shear rate is maintained.

To prevent the inevitable cold slug reaching the moulding from the injection nozzle, the gate should always be extended so that the cold slug can be intercepted. This extension should have roughly the same diameter as the gate to ensure that the cold slug really is retained.

When moulding partially crystalline, unreinforced polymers, the minimum gate thickness should be 50 per cent of the wall thickness of the moulded part. This would also be adequate for reinforced compounds. To minimise the risk of damage to the fibres and also bearing in mind the higher viscosity of these compounds, the gate thickness should be up to 75 per cent of the wall thickness of the moulded part.

Gate length is especially crucial. This should be <1 mm to prevent premature solidification of the gate. The mould will heat up near the gate, so that the holding pressure is at its most effective.

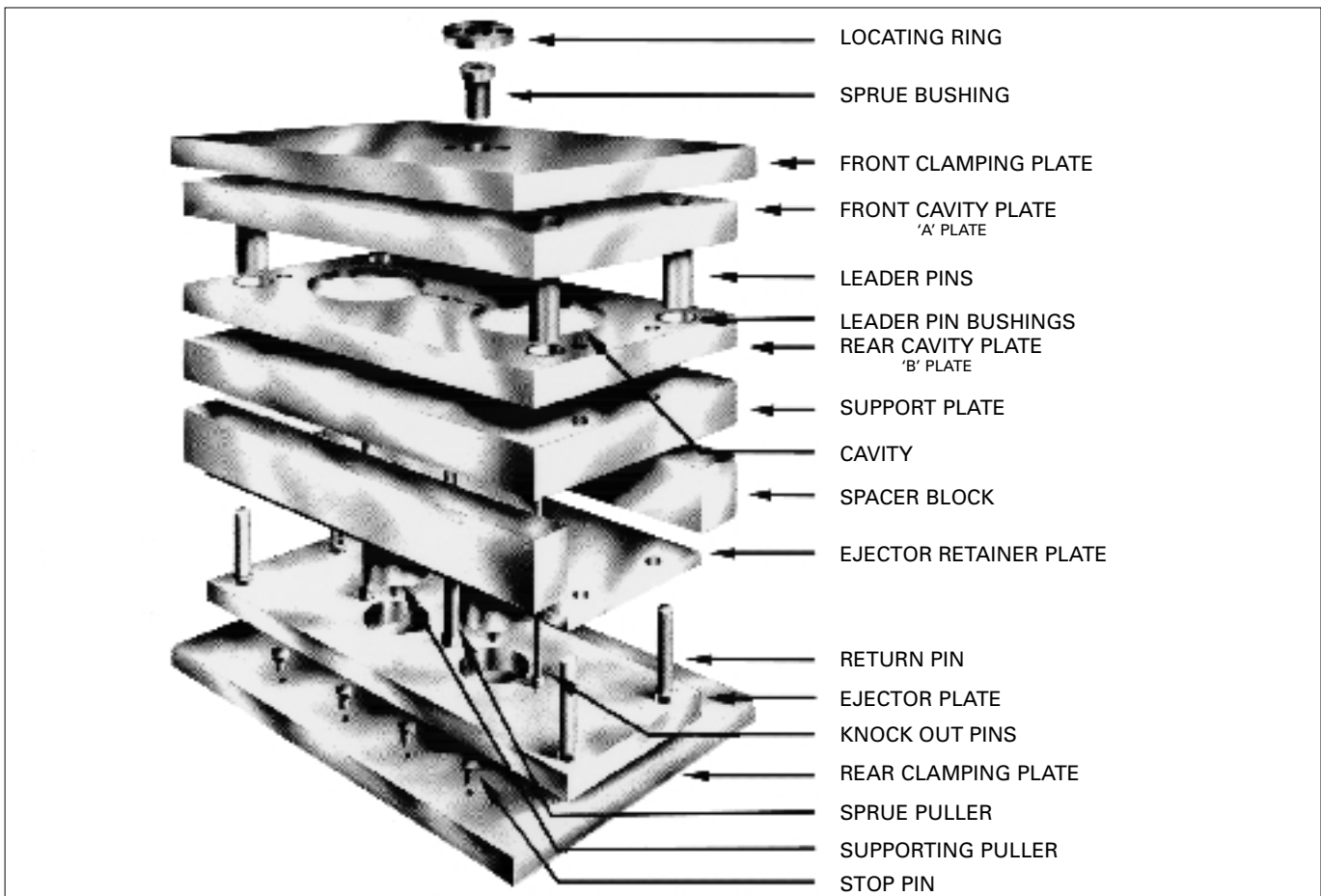

Fig. 4.3 Exploded view of mould

All types of gates have been used successfully with DuPont polyester resins. The location, size and number of gates are important considerations.

Round gates are preferred for automatic three-plate (pin gates) and tunnel-gated (submarine gates) moulds because of ease of gate separation and part ejection.

In addition to round and rectangular gates, there are many other types of gates such as film gate, fan gate, rectangular gate illustrated on Figure 4.4. “Banana” gates however are not recommended.

Generally, gate thickness should be 50% to 75% of the part thickness. Figures 4.6, 4.7 and 4.8 show design recommendations for the most commonly used gate designs.

To summarise the basic rules:

- always provide a means of intercepting the cold slug;
- make the runner diameter bigger than the moulded part wall thickness;
- gate thickness should be at least 50% of the moulded part wall thickness.

4.4 Hot runner

When injection moulding partially crystalline engineering thermoplastics like Rynite PET and Crastin PBT, the choice of the correct hot runner system and its installation determines the function of mould and moulded part quality. Hot runner tools are thermally very complex systems. Therefore it is important to consult the hotrunner manufacturer in order to get advice on the manifold and nozzle type selection, dependant on the chosen polymer.

Some basic rules can be applied when planning a hot-runner mould with semi-crystalline PET and PBT: The manifold must be naturally balanced. Rheological balancing (i.e. adapting nozzle or subrunner gate size) can only optimize for either equal Filling Time (dynamic balancing) or Hold Pressure Level (static balancing). Both together are often contradictory.

Direct gating on the part should be avoided:

- for small shot weights or long cycle times (total hold up time above 10 minutes);
- for esthetical parts, as surface defects may occur in gate area;
- for safety relevant parts, as there is always a cold or inhomogeneous slug coming from the nozzle tip, which might move to a mechanically critical area;

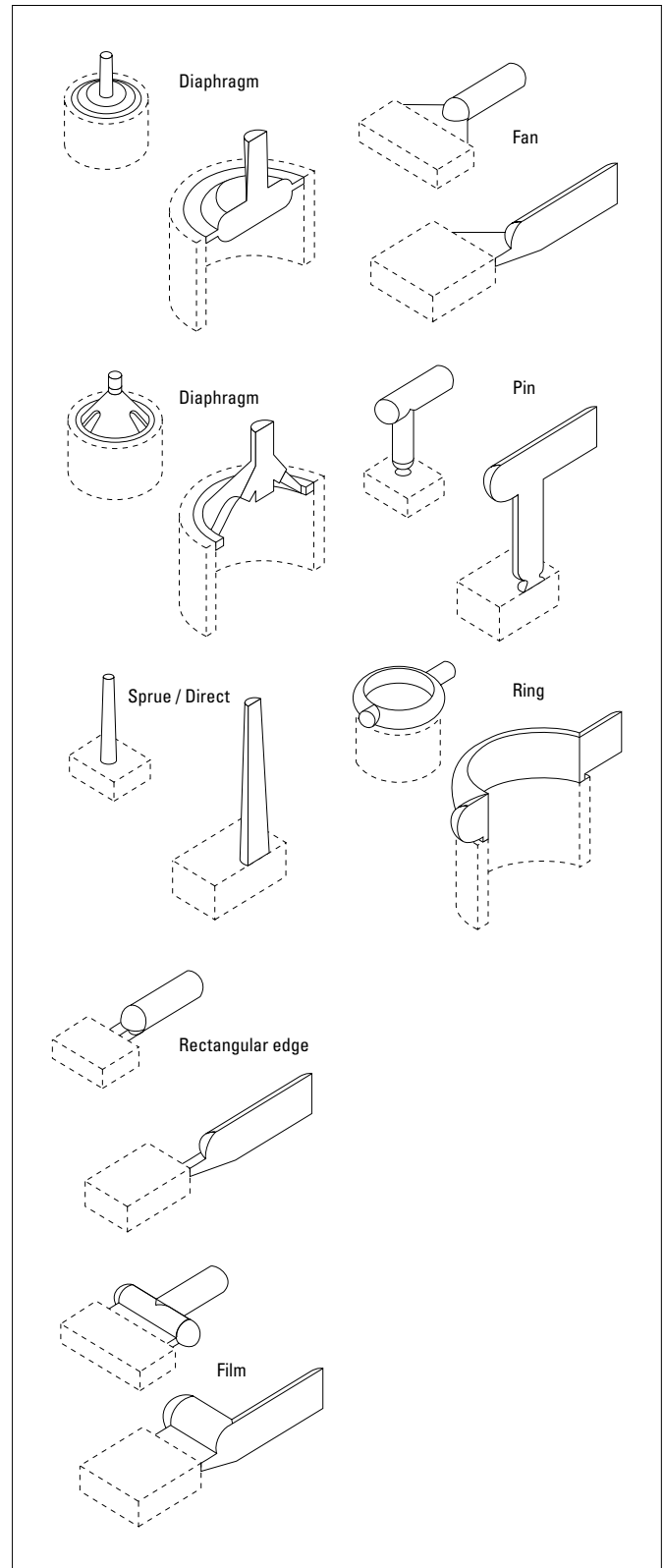

Fig. 4.4 Different types of gate

- when no hanging over residue or filaments from gate breakage can be accepted.

Manifold and nozzles must be perfectly streamlined, in order to avoid any hold-up spot.

Externally heated manifolds are preferred versus internally heated ones, as they allow better streamlining at intersections and generate less shear for the polymer.

The thermal balance must be optimal. Temperature differentials of more than 20 K can not be tolerated in a hotrunner system. Therefore it is essential to have the right combination of hardware (manifold, nozzles, heaters), software (heating control) and set-up (optimum thermal insulation between hotrunner and mould).

“Self-insulating” nozzles should be avoided. This kind of nozzle requires the polymer to flow into a calotte shaped gap between nozzle tip and mould surface, in order to optimize the thermal insulation of the nozzle tip. However, with semi-crystalline polymers, like PBT and PET, the resin in this gap stays in most systems at a temperature above the freezing point and will therefore thermally degrade. This can create surface defects in irregular intervals.

“Free Flow” nozzle types are preferred to those with torpedos at the tip, unless there are specific requirements for the breaking at the gate area.

Specific abrasion resistant metals or treatments are preferred for reinforced grades, specifically at the nozzle tip, where shear is highest. Hard metal tips have led to much longer life-times of the tip.

Nozzle tips should be exchangeable. This allows an easier control of abrasion, and reduces the cost in case of necessary modifications.

When heating up a hotrunner which contains CRASTIN® or RYNITE®, it is important first to heat up to approximately 20 K below the melting point, thus 210°C for CRASTIN® and 230°C for RYNITE® and to wait at least 30 minutes at this temperature before heating up to operation temperature. This allows to soak in the heat and to get a convenient heat balance. Modern controllers allow such an automated stepwise start-up procedure.

When there is a doubt about a hold-up spots in the hotrunner, it is advisable to make a colour change on the cylinder and then to mould during 10 minutes continuously. Then the system can be shut down and the hotrunner/nozzle should be disassembled to identify the spots, which still contain the first colour. With the help of the hotrunner manufacturer it should be possible to improve the streamlining of the hotrunner/nozzle.

4.5 Venting

Inadequate mould venting can cause the following problems:

- Poor weld line strength.
- Discolouration (burning).
- Erosion or corrosion of the mould.
- Dimensional variation on the moulded part.
- Short shots.

Both cavities and runners should be vented at the parting line or at the ejector as recommended on Fig. 4.11 and 4.12.

The area of the vent must be large enough ($W \times d$) to prevent a rise of gas pressure in the mould cavity. The vent length should not exceed 1 mm. The area of the escape passage leading from the vent should increase in proportion to its distance from the cavity edge. In the case of low viscosity grades and where there must be a minimum of flash, vent slits should be shallower to start with.

4.6 Draft angles

Mould surfaces that are perpendicular to the parting line should be tapered to allow easy part ejection. These include ribs, bosses and sides. A taper (draft angle) of 0,5 to 1° is usually satisfactory with CRASTIN® and RYNITE®.

4.7 Sharp corners

Part design and mould finish should consider the basic rule to rounden sharp corners. As shown in Fig. 4.9, unreinforced resins are by far more sensitive to the notch effect of sharp corners.

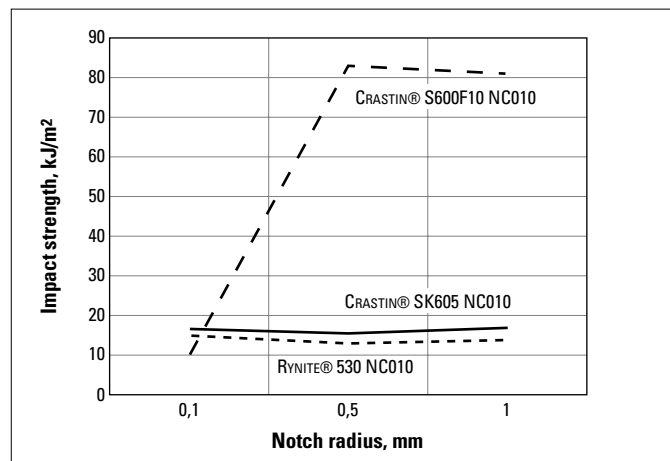

Fig. 4.9 Effect of notch radius on impact performance

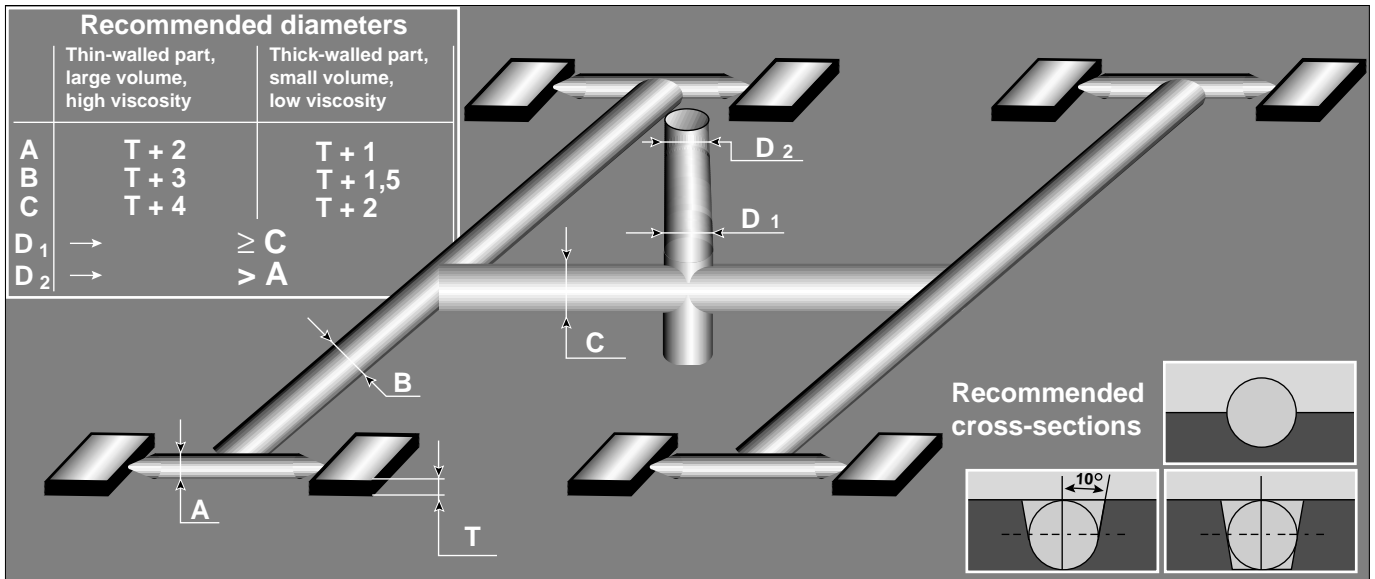

Fig. 4.5 Design of a multiple runner

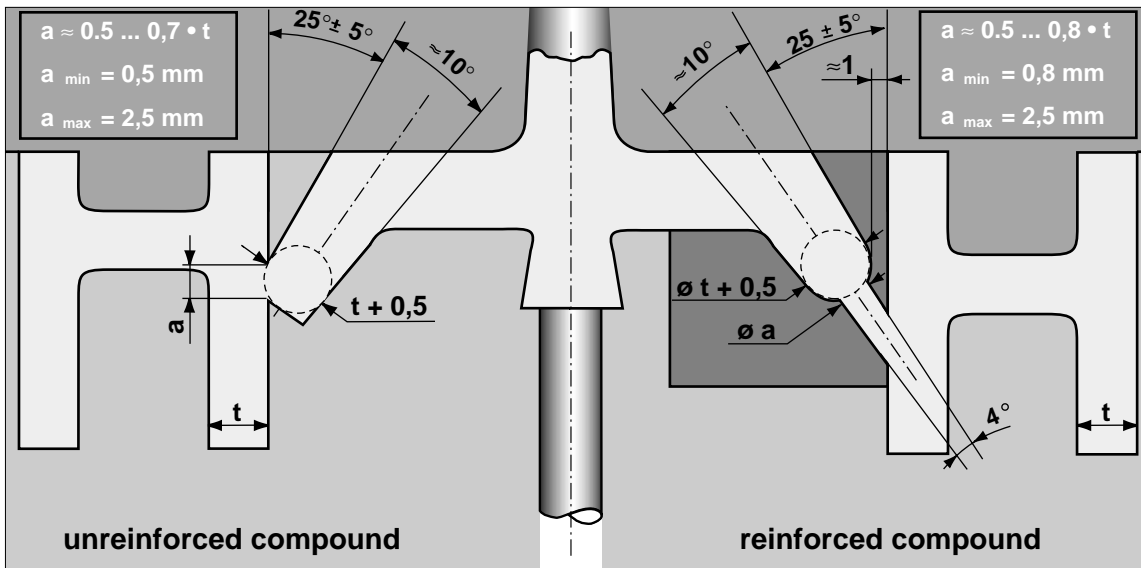

Fig. 4.6 Tunnel gates

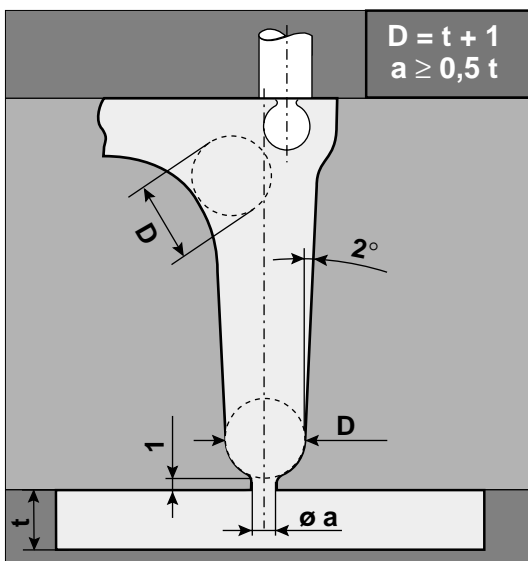

Fig. 4.7 3-Plate gate

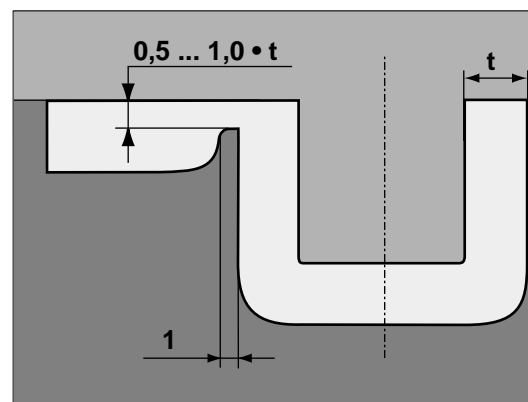

Fig. 4.8 Direct gate

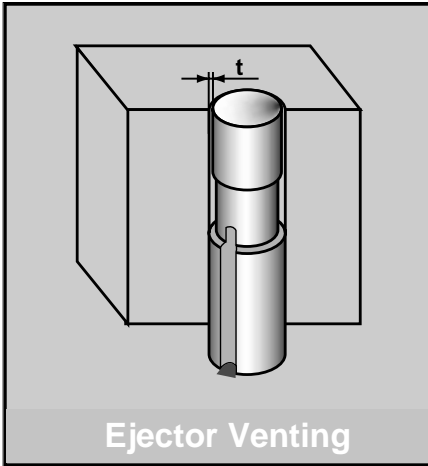

Fig. 4.10 **Ejector Venting**

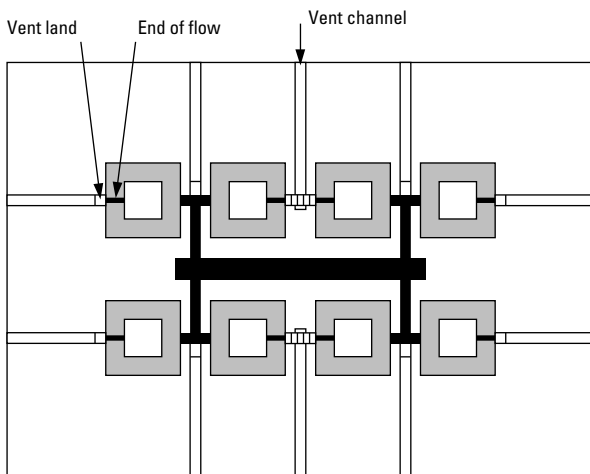

Fig. 4.11 **Vent geometries ejector**

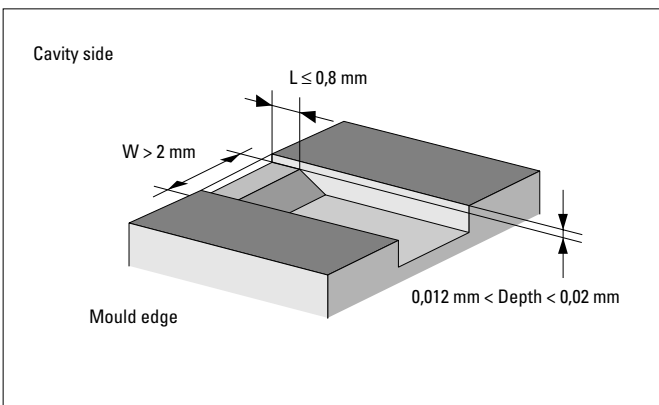
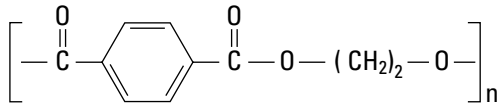

Fig. 4.12 **Parting Line Venting**

5 Material behaviour

5.1 Chemical structure

The chemical composition of the RYNITE® PET is as follows:



Whereas the chemical structure of CRASTIN® PBT is:

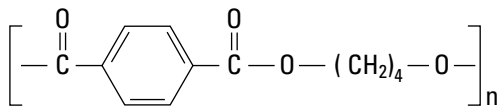

RYNITE® PET exhibits higher modulus, strength, melting point, glass transition temperature and lower mobility – slower crystallisation compare to CRASTIN® PBT, since RYNITE® PET units is shorter than CRASTIN® PBT.

5.2 Flow length

CRASTIN® and RYNITE® polyester resins have very good flow properties. Parts with long flow paths and narrow wall thickness are easily moulded. The good flow properties also contribute to achieving high surface finish quality, even with glass fibre reinforced products. Mould details are precisely reproduced.

Flow length data are generated on moulds with a “spiral” or “snake” flow pattern. Data from one study can vary a lot compared to some from other studies, as flow length is highly dependent on:

- moulding parameters (melt temperature, moisture, hold up time);
- mould layout (channel width, gate design);
- type of moulding machine (valve response time, ability to avoid hydraulic pressure peaks at v/p switch point).

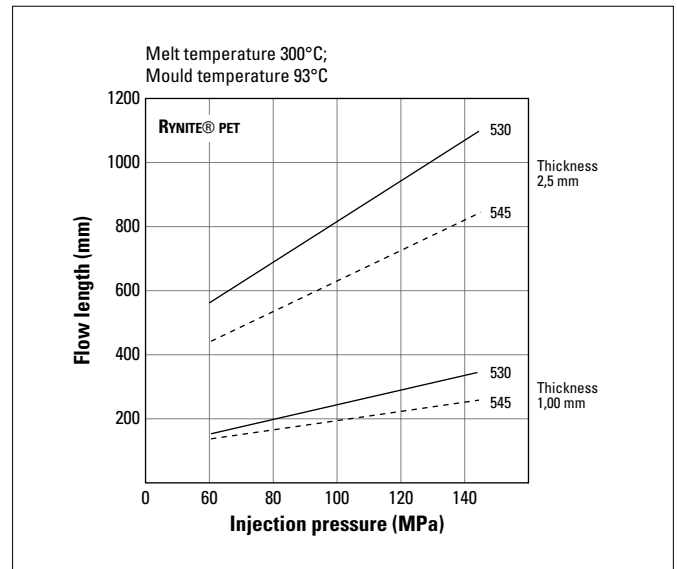

Fig. 5.1 Flow length of RYNITE® resins

Figure 5.1 shows the flow length of RYNITE® resins using various moulding conditions.

Figure 5.2 shows the flow properties of standard CRASTIN® types. The indicated flow lengths, at wall thickness of 1, 2 and 3 mm, were determined with the aid of a test spiral.

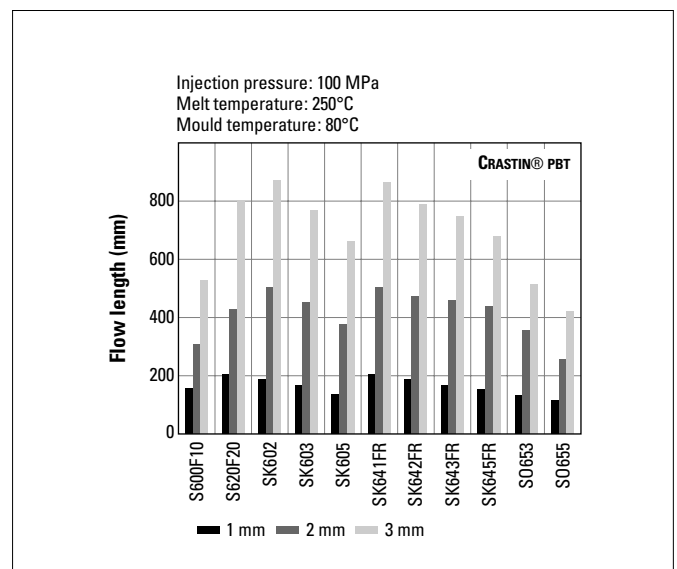

Fig. 5.2 Flow length with wall thickness of 1, 2 and 3 mm for several grades of CRASTIN®

Figures from a.1 to a.66 show flow length in the sections up to 1 mm. On page 20, the table 5.1 indicates the page where the flow length diagram of each polyester grade may be found.

Table 5.1 Thin-flow data are available for these fine products

	No. fig	page		No. fig.	page		No. fig	page
CRASTIN® 6130	a.1	24	CRASTIN® T803	a.23	27	CRASTIN® LW9330FR	a.45	31
CRASTIN® S600F20	a.2	24	CRASTIN® T805	a.24	27	CRASTIN® HTI668FR	a.47	31
CRASTIN® S600F10	a.3	24	CRASTIN® S0653	a.25	28	CRASTIN® HTI619	a.46	31
CRASTIN® S620F20	a.4	24	CRASTIN® S0655	a.26	28	CRASTIN® HTI681FR	a.48	31
CRASTIN® SK601	a.5	24	CRASTIN® CE1064	a.27	28	CRASTIN® HTI688FR	a.49	32
CRASTIN® SK602	a.6	24	CRASTIN® S650FR	a.28	28	CRASTIN® SK662FR	a.50	32
CRASTIN® SK603	a.7	25	CRASTIN® S680FR	a.29	28	CRASTIN® SK665FR	a.51	32
CRASTIN® SK605	a.8	25	CRASTIN® T850FR	a.30	28	CRASTIN® SK655FR1	a.52	32
CRASTIN® SK608	a.9	25	CRASTIN® SK641FR	a.31	29	RYNITE® 415HP	a.53	32
CRASTIN® SK609	a.10	25	CRASTIN® SK642FR	a.32	29	RYNITE® 408	a.54	32
CRASTIN® HR5015F	a.11	25	CRASTIN® SK643FR	a.33	29	RYNITE® 520	a.55	33
CRASTIN® HR5030F	a.12	25	CRASTIN® SK645FR	a.34	29	RYNITE® 530	a.56	33
CRASTIN® LW9020	a.13	26	CRASTIN® CE7910	a.35	29	RYNITE® 545	a.57	33
CRASTIN® LW9030	a.14	26	CRASTIN® CE7931	a.36	29	RYNITE® 555	a.58	33
CRASTIN® LW9320	a.15	26	CRASTIN® SK645FRC	a.37	30	RYNITE® 935	a.59	33
CRASTIN® LW9330	a.16	26	CRASTIN® SK673GW	a.38	30	RYNITE® 940	a.60	33
CRASTIN® SK9215	a.17	26	CRASTIN® T841FR	a.39	30	RYNITE® 530CS	a.61	34
CRASTIN® SK9220	a.18	26	CRASTIN® T843FR	a.40	30	RYNITE® 536CS	a.62	34
CRASTIN® SK9230	a.19	27	CRASTIN® T845FR	a.41	30	RYNITE® FR515	a.63	34
CRASTIN® LW9236	a.20	27	CRASTIN® LW9020FR	a.42	30	RYNITE® FR530L	a.64	34
CRASTIN® ST820	a.21	27	CRASTIN® LW9030FR	a.43	31	RYNITE® FR543	a.65	34
CRASTIN® T801	a.22	27	CRASTIN® LW9320FR	a.44	31	RYNITE® FR943	a.66	34

Table 5.2 Measured shrinkage values on plaques of RYNITE® moulded under standard conditions

RYNITE® grades	End gated plate 76,2 × 127 × 3,2 mm		End gated plate 76,2 × 127 × 1,6 mm	
	shrinkage in flow direction (%)	shrinkage in transverse direction (%)	shrinkage in flow direction (%)	shrinkage in transverse direction (%)
520	0,35	0,90	0,23	0,82
530	0,25	0,80	0,18	0,78
545	0,20	0,75	0,15	0,67
555	0,20	0,70	0,13	0,66
FR515	0,50	0,95	0,34	0,69
FR530L	0,25	0,75	0,16	0,68
FR543	0,20	0,65	0,12	0,47
FR943	0,35	0,70	0,22	0,57
408	0,20	0,75	0,21	0,63
415HP	0,40	0,95	0,24	0,67

5.3 Shrinkage

For amorphous thermoplastics, shrinkage is caused primarily by contraction of the moulded part as it cools to room temperature.

In semi-crystalline thermoplastics, which include CRASTIN® and RYNITE® grades, shrinkage is also influenced considerably by the crystallization of the polymer. The degree of crystallization depends largely on the transient and local temperature changes in the moulding. High mould temperatures and heavy wall thickness (high heat content of the melt) promote crystallization and therefore increase shrinkage.

Optimum runner and gate design, as well as adequate hold pressure time are necessary in order to achieve minimum shrinkage with those semi-crystalline polymers.

a. Shrinkage of RYNITE®

The mould shrinkage of RYNITE® glass-reinforced resins depends on the orientation of the glass fibres, part thickness and processing conditions. RYNITE® glass-reinforced resins shrink less in the flow direction than in the transverse direction.

Special grades of RYNITE® are available with a smaller differential shrinkage than RYNITE® 530 and 545. These grades are intended for applications where minimum warpage is needed.

For complex precision parts, prototype moulds (cavities) should be utilised to obtain more accurate dimensional data.

Table pages 35-36 of recommended processing table contain ISO shrinkage on 2 × 60 × 60 mm plate. Table 5.2 contains shrinkage data on a plate 76,2 × 127 mm.

b. Shrinkage of CRASTIN®

The influence of wall thickness on shrinkage of unreinforced CRASTIN® is shown in Figure 5.3. This shows the shrinkage of plates 100 × 100 mm, with a wall thickness of 1-4 mm, using standard processing conditions.

The shrinkage behaviour of filled CRASTIN® types or of unreinforced, flame-retardant CRASTIN® types is similar to that of CRASTIN® S600F10.

For glass-fibre reinforced CRASTIN®, shrinkage is considerably influenced by the direction in which the glass-fibres are oriented. As a result, there is a difference in shrinkage parallel to and at right angles to the direction of flow and this makes accurate prediction of the shrinkage difficult. Depending on the fibre orientation, which is determined by the way in which the mould fills, shrinkage can also occur

between the longitudinal and transverse shrinkage shown in Figure 5.4. In extreme cases, the difference in shrinkage may be greater than shown.

This depends on the degree to which the glass-fibres orient themselves as determined by the design of the part and the position of the gate.

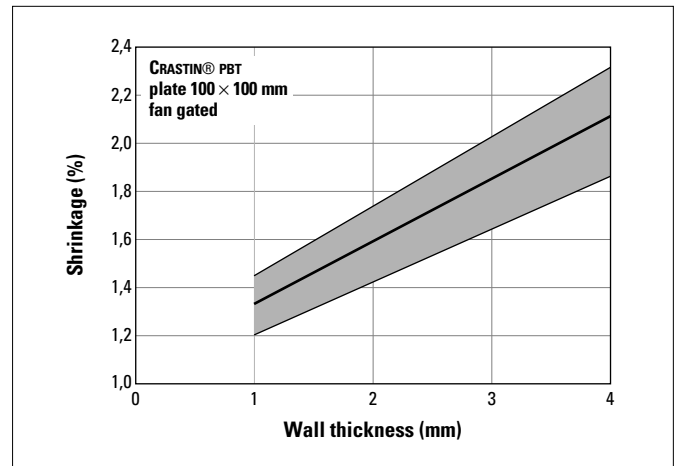

Fig 5.3 Shrinkage of unreinforced (e.g. S600F10) and filled (e.g. S0655) CRASTIN® types as a function of wall thickness. Not valid for toughened grades

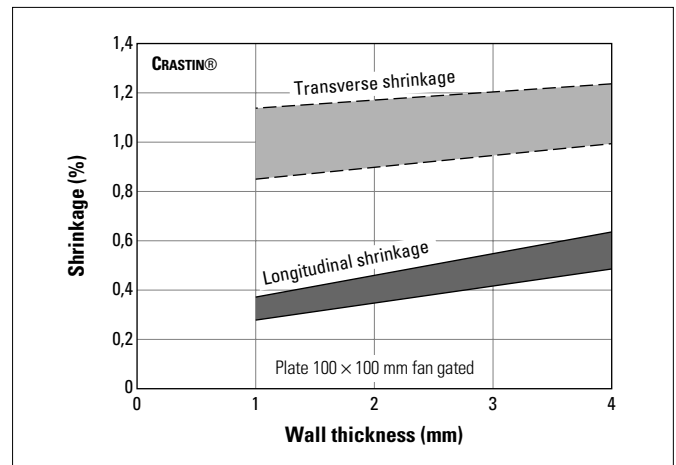

Fig 5.4 Shrinkage of 30% glass-fibre reinforced CRASTIN® types (e.g. SK605, SK645FR) as a function of wall thickness

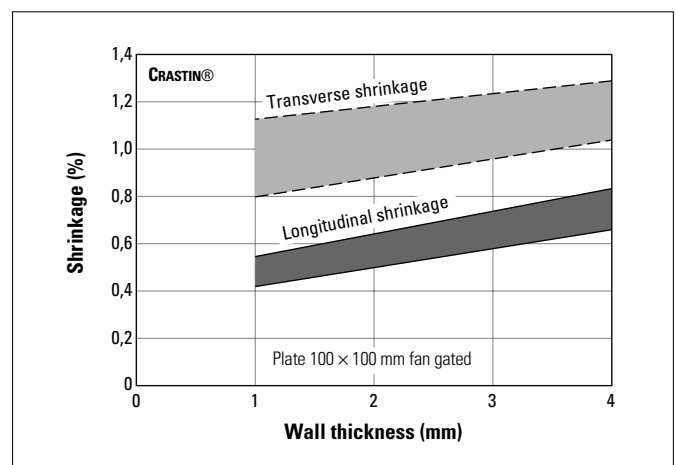

Fig 5.5 Shrinkage of 15% glass-fibre reinforced CRASTIN® types (e.g. SK605, SK645 FR) as a function of wall thickness

5.4 Post-shrinkage

Post-shrinkage can be defined as the dimensional change (in %) of a moulded part measured at $23 \pm 2^\circ\text{C}$ after annealing for a specific period at a specific temperature.

Table “pro list” contains shrinkage values after annealing (= moulding shrinkage + post-shrinkage). The annealing conditions of those plates were 3 h/ 160°C for CRASTIN® PBT and 3 h/ 180°C for RYNITE® PET.

Complex parts may require lower annealing temperatures and time, in order to minimize deformation at annealing temperatures. It is recommended to conduct some trials in order to find optimum annealing conditions in case that annealing should be necessary.

Within the group of semi-crystalline thermoplastics, CRASTIN® types exhibit low post-shrinkage values. As can be seen in Figures 5.6 and 5.7, post-shrinkage is an inverse function of processing or mould shrinkage. Increasing the mould temperature reduces post-shrinkage for a given, constant conditioning temperature. However, it increases as the wall thickness increases. In the case of glass-fibre reinforced types, these effects are minimal.

This means that precision parts with very narrow tolerances should be produced using higher mould temperatures, particularly if the parts have thin walls. The degree of crystallinity will then be sufficiently high so that little or no post-shrinkage occurs if the parts are used at continuous high temperatures.

As well as processing shrinkage, glass-fibre reinforced products also exhibit different degrees of post-shrinkage in parallel and normal orientations (Figure 5.7).

Comparison of Figures 5.6 and 5.7 shows that glass-fibre reinforced CRASTIN® and RYNITE® types exhibit even lower post-shrinkage than the unreinforced or filled types.

At a given conditioning temperature, post-shrinkage is virtually complete after 24 hours.

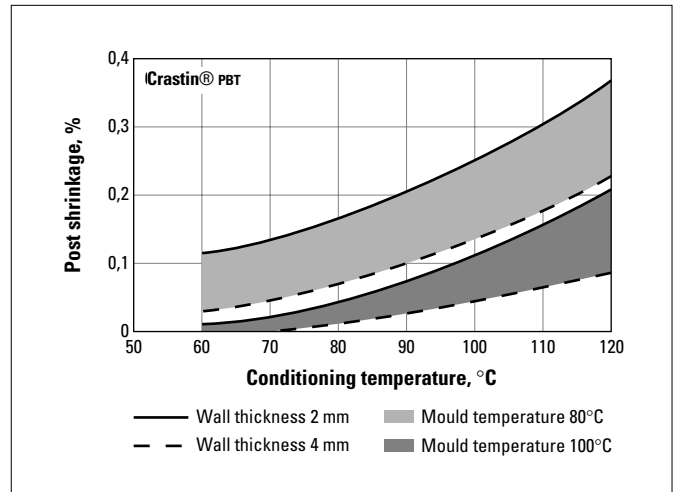

Fig 5.6 Post-shrinkage of unreinforced (e.g. S600F10) and filled (e.g. S0655) CRASTIN® types, as a function of conditioning temperature, mould temperature and wall thickness

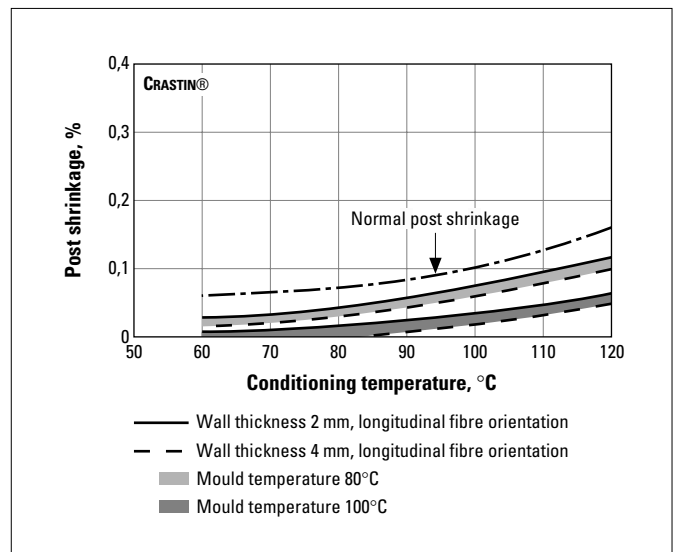

Fig 5.7 Post-shrinkage of 30% glass-fibre reinforced CRASTIN® types (e.g. SK605, SK645 FR) as a function of conditioning temperature, wall thickness and mould temperature

6 Auxiliary operations

6.1 Regrind

Only regrind from optimally processed original material should be used.

The actual amount of regrind which can be added must be determined for each part by testing. Only the operational and performance requirements of a moulded part can determine the amount of regrind that can be acceptable.

Because of the irreversible chemistry of polyester resins, material that has been previously degraded because of its high moisture content and/or too long Hold-Up Time (HUT) in the barrel can **not** be re-used. Moulded part that become brittle as a result of poor material handling (too high moisture content in the granules) or material left in the barrel (too long HUT) must be discarded and **not** be re-used, thus avoiding any dramatic deterioration in properties when mixed with good regrind and/or virgin resin.

In order to keep the loss of strength and toughness at a low level, not more than 30% by weight of regrind should be added to unreinforced products. In the case of glass-fibre reinforced types, increased loss of strength must be expected due to the reduction of fibre length which occurs during regrinding. For this reason, not more than 25% by weight of regrind should be added to reinforced materials. The reduction in the flexural and impact strength of CRASTIN® SK605 with various regrind percentages and repeated use is shown in Figure 6.1.

In the case of parts subjected to mechanical loads, regrind should be used only rarely. A higher amount of regrind is feasible, for example, when in addition to electrical insulating properties, the part needs only a high heat deflection temperature. Recycled material should have approximately the same granule size as fresh granulate. Grinder screens with a mesh size of about 5 mm yield a grain size of approximately 3 mm in diameter.

A screen with a mesh of approximately 2,5 mm can be used for removing dust particles in the regrind. Before processing, the regrind should be dried to avoid the possibility of degradation due to the presence of moisture in the granulate.

6.2 Colouring

A range of cube-blended standard colours is available for certain polyesters. The freedom of design is even greater in that almost any colouring system can be used: dry pigment, paste, liquid colour or dyes. But such systems can also lead to variations in properties and/or performance.

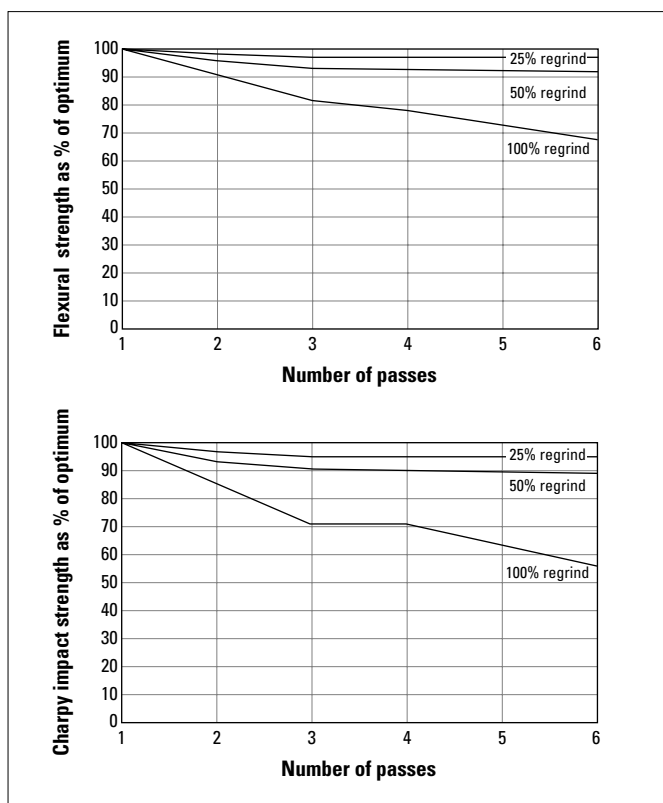

Fig 6.1 Reduction of the flexural and impact strength of CRASTIN® SK605 for various regrind percentages and repeated use

When using masterbatch or dry pigments, special attention should be given to these aspects:

- The dry pigments or masterbatch used have to be chemically compatible with polyester resins and must have good thermal stability above the processing temperature of the resin.
- Pigments usually affect the crystallisation rate and consequently the shrinkage. Additionally the carrier of liquid colours has an effect on moulding.
- The carrier can be considered as a surface lubricant, which may, theoretically, cause screw slippage leading to filling problems.
- The key issue when moulding with colouring techniques is to ensure a homogeneous dispersion and mixing of the pigment in the polymer matrix.

When using a colouring technique, the following points should be carefully observed:

- Use of reasonable ratio between polymer and masterbatch.
- Use of high-compression screws.
- Use of screw retraction stroke less than 30% of the maximum screw retraction of the machine.

Important note

DuPont cannot give any guarantee for the performance and properties of moulded parts when DuPont manufactured polyester resins are mixed with other products like masterbatches, liquid pigments or colourants.

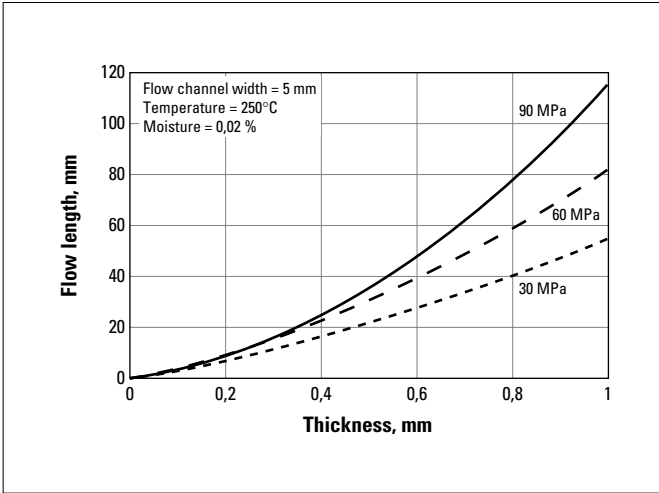

Fig. a.1 **CRASTIN® 6130 NC010**

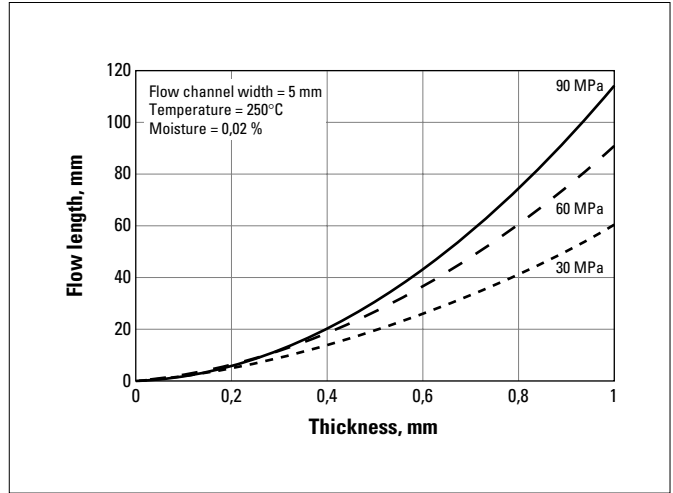

Fig. a.2 **CRASTIN® S600F20 NC010**

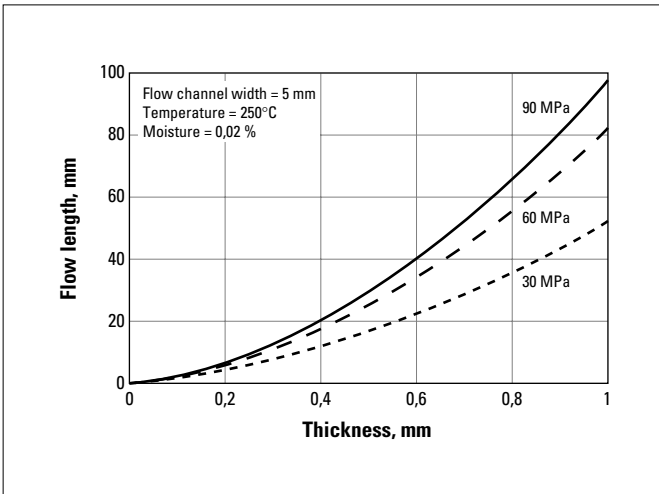

Fig. a.3 **CRASTIN® S600F10 NC010**

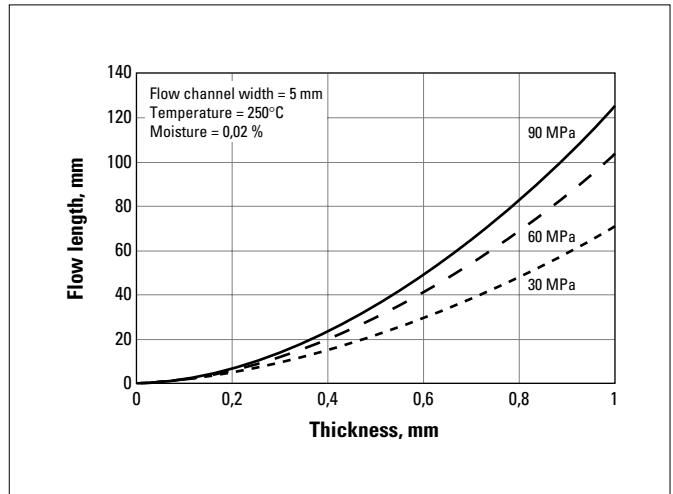

Fig. a.4 **CRASTIN® S620F20 NC010**

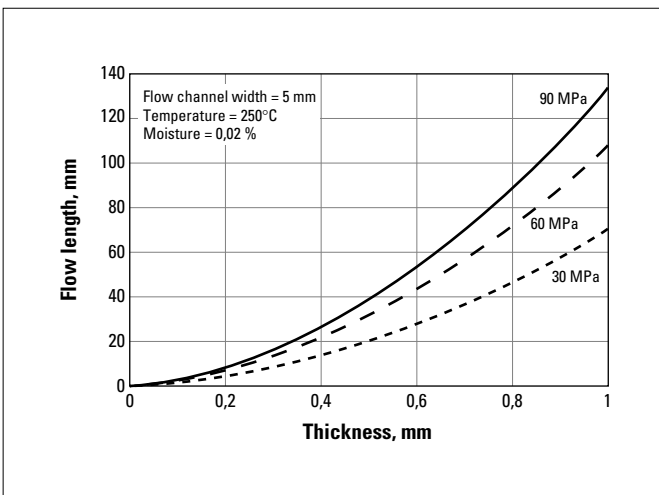

Fig. a.5 **CRASTIN® SK601 NC010**

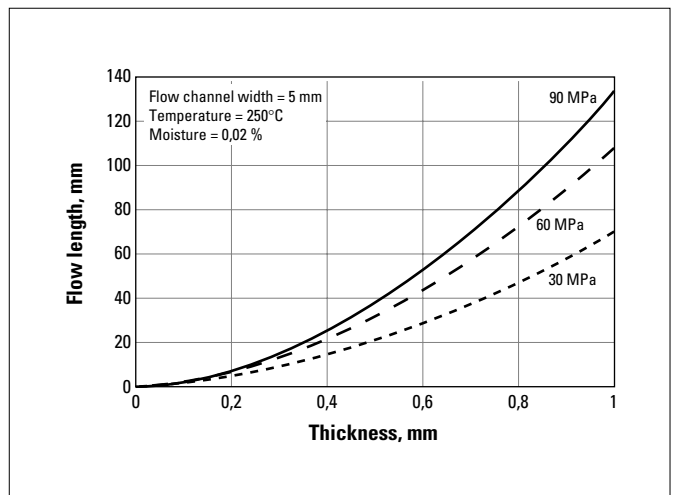

Fig. a.6 **CRASTIN® SK602 NC010**

The information provided in this documentation corresponds to our knowledge on the subject at the date of its publication. This information may be subject to revision as new knowledge and experience becomes available. The data provided fall within the normal range of product properties and relate only to the specific material designated; these data may not be valid for such material used in combination with any other materials or additives or in any process, unless expressly indicated otherwise. The data provided should not be used to establish specification limits nor used alone as the basis of design; they are not intended to substitute for any testing you may need to conduct to determine for yourself the suitability of a specific material for your particular purposes. Since DuPont cannot anticipate all variations in actual end-use conditions DuPont makes no warranties and assumes no liability in connection with any use of this information. Nothing in this publication is to be considered as a license to operate under or a recommendation to infringe any patent rights.

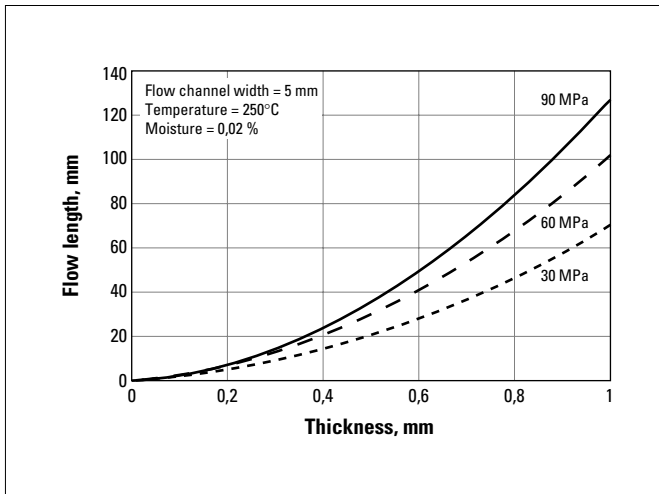

Fig. a.7 **CRASTIN® SK603 NC010**

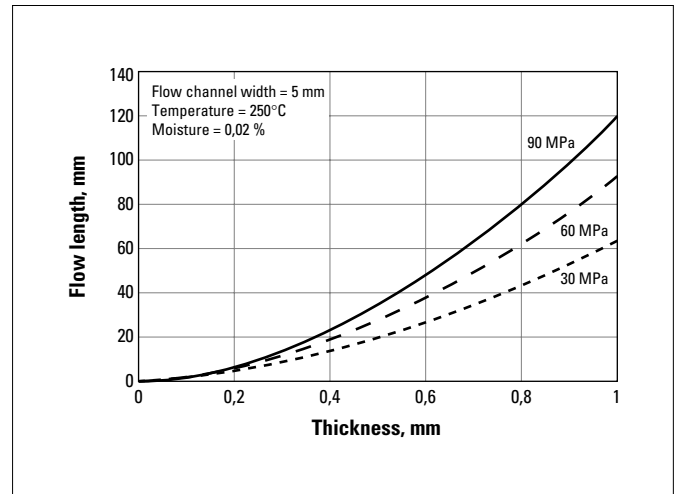

Fig. a.8 **CRASTIN® SK605 NC010**

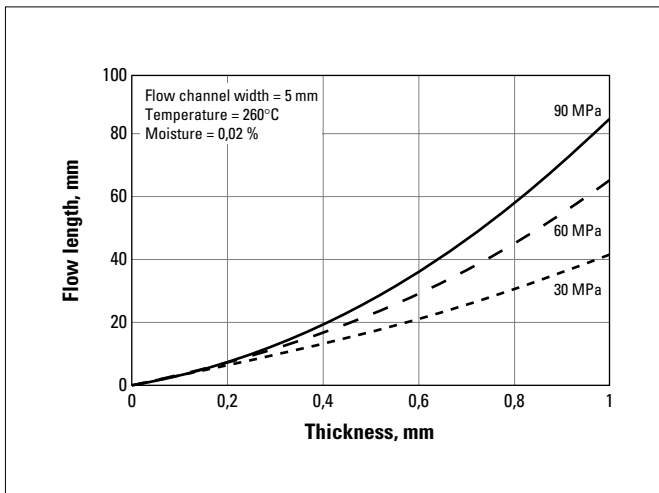

Fig. a.9 **CRASTIN® SK608 BK**

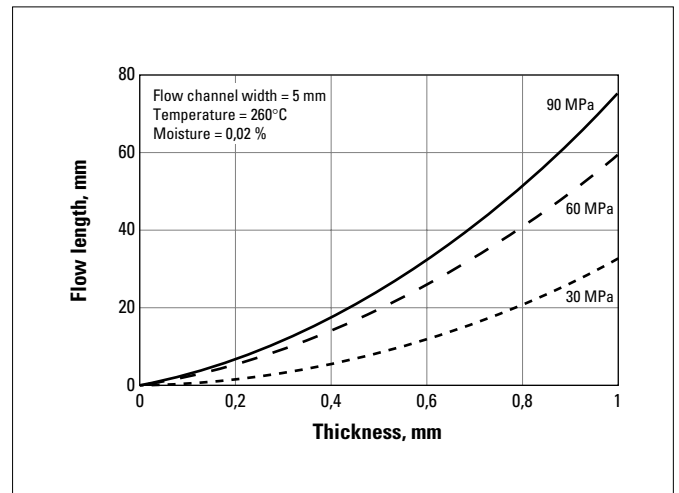

Fig. a.10 **CRASTIN® SK609 NC010**

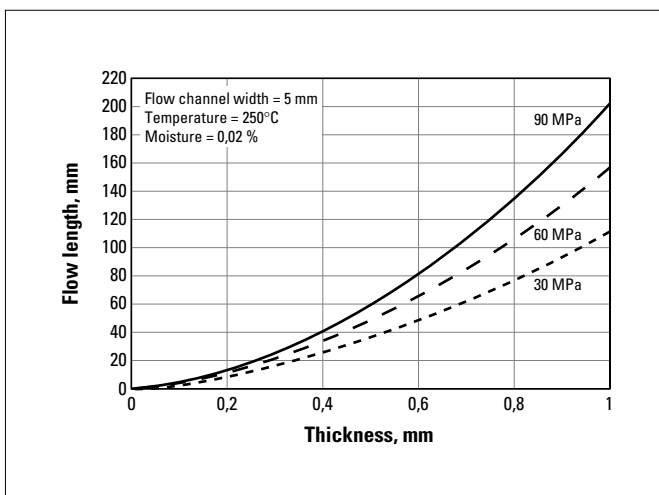

Fig. a.11 **CRASTIN® HR5015F BK**

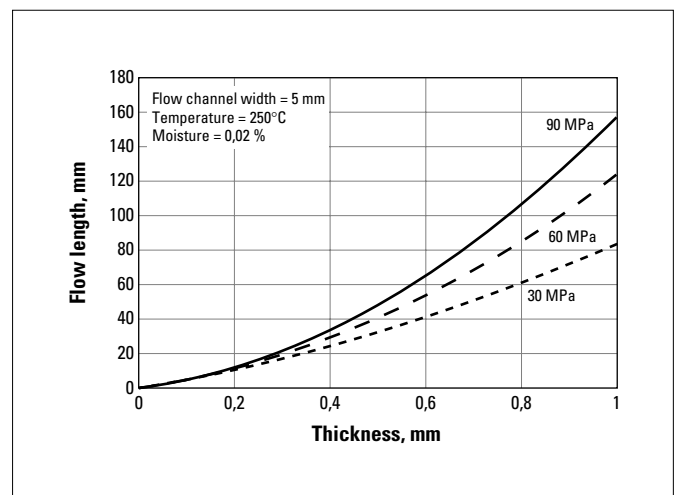

Fig. a.12 **CRASTIN® HR5030F BK**

The information provided in this documentation corresponds to our knowledge on the subject at the date of its publication. This information may be subject to revision as new knowledge and experience becomes available. The data provided fall within the normal range of product properties and relate only to the specific material designated; these data may not be valid for such material used in combination with any other materials or additives or in any process, unless expressly indicated otherwise. The data provided should not be used to establish specification limits nor used alone as the basis of design; they are not intended to substitute for any testing you may need to conduct to determine for yourself the suitability of a specific material for your particular purposes. Since DuPont cannot anticipate all variations in actual end-use conditions DuPont makes no warranties and assumes no liability in connection with any use of this information. Nothing in this publication is to be considered as a license to operate under or a recommendation to infringe any patent rights.

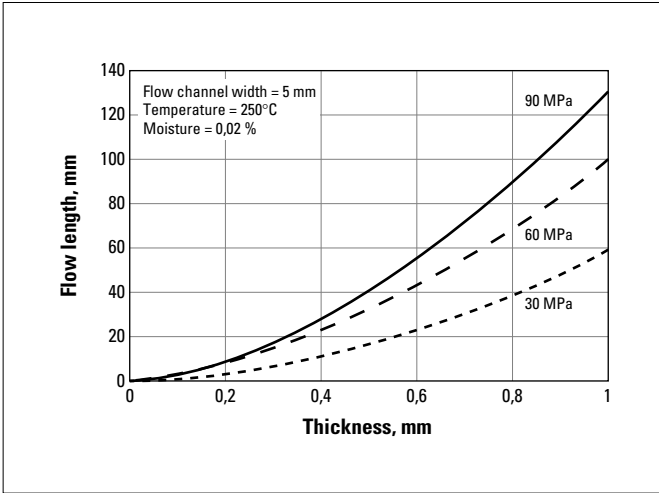

Fig. a.13 CRASTIN® LW9020 NC010

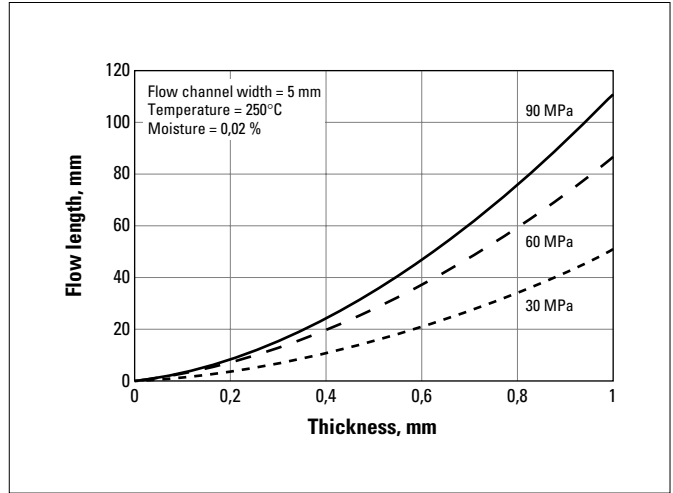

Fig. a.14 CRASTIN® LW9030 NC010

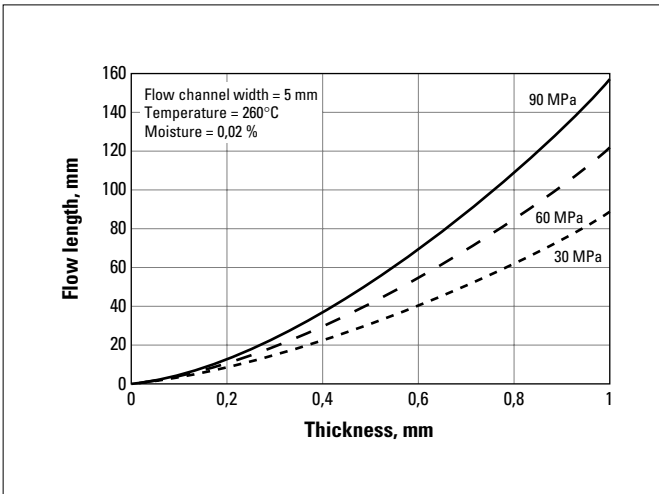

Fig. a.15 CRASTIN® LW9320 NC010

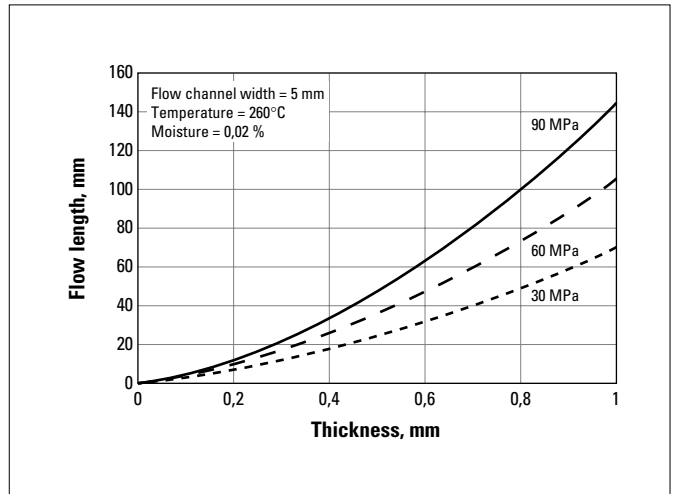

Fig. a.16 CRASTIN® LW9330 NC010

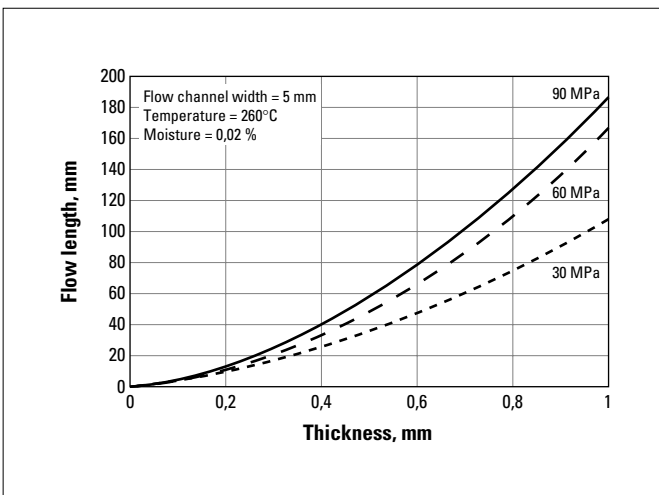

Fig. a.17 CRASTIN® SK9215 NC010

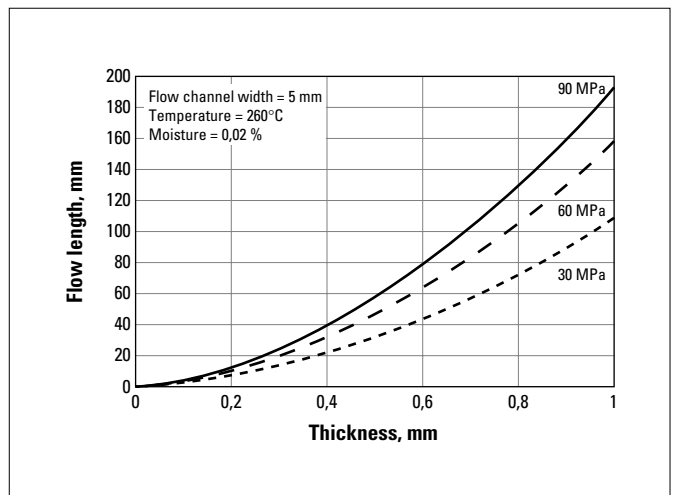

Fig. a.18 CRASTIN® SK9220 NC010

The information provided in this documentation corresponds to our knowledge on the subject at the date of its publication. This information may be subject to revision as new knowledge and experience becomes available. The data provided fall within the normal range of product properties and relate only to the specific material designated; these data may not be valid for such material used in combination with any other materials or additives or in any process, unless expressly indicated otherwise. The data provided should not be used to establish specification limits nor used alone as the basis of design; they are not intended to substitute for any testing you may need to conduct to determine for yourself the suitability of a specific material for your particular purposes. Since DuPont cannot anticipate all variations in actual end-use conditions DuPont makes no warranties and assumes no liability in connection with any use of this information. Nothing in this publication is to be considered as a license to operate under or a recommendation to infringe any patent rights.

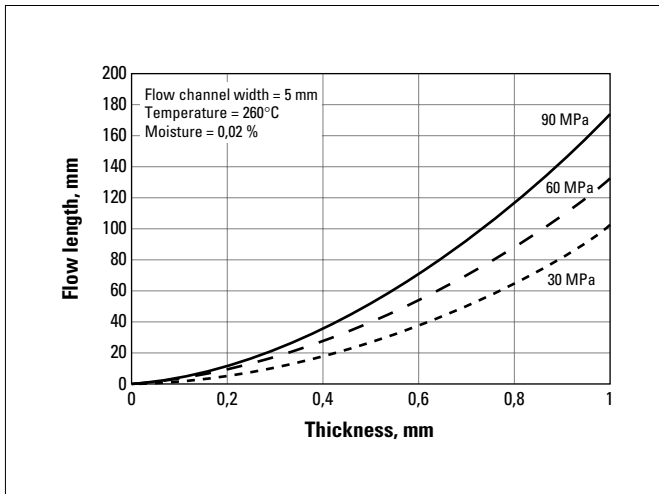

Fig. a.19 CRASTIN® SK9230 NC010

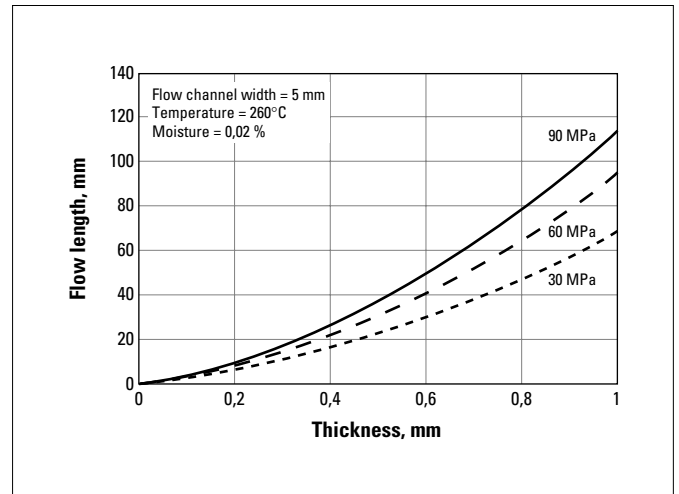

Fig. a.20 CRASTIN® LW9236 NC010

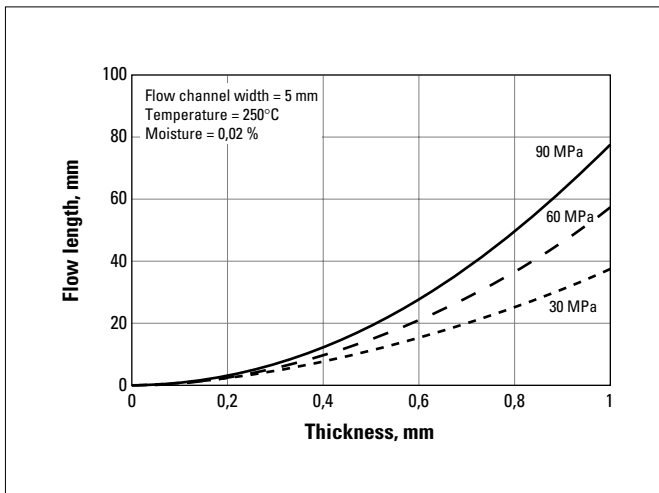

Fig. a.21 CRASTIN® ST820 NC010

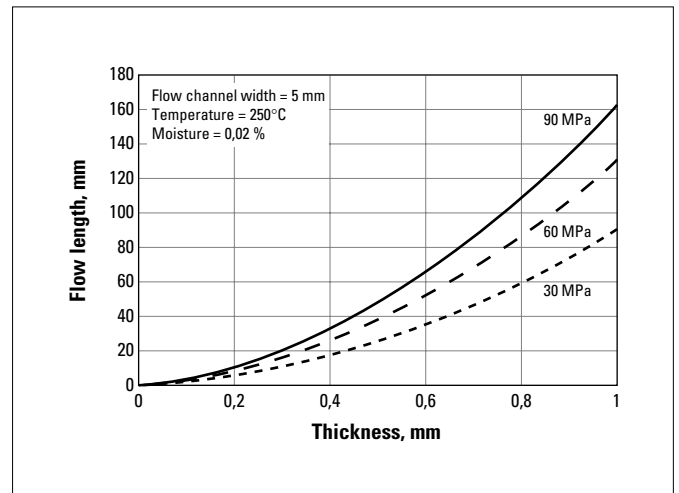

Fig. a.22 CRASTIN® T801 NC010

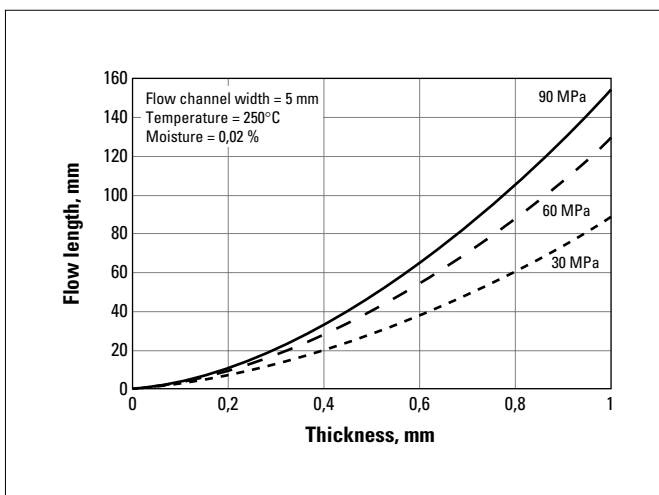

Fig. a.23 CRASTIN® T803 NC010

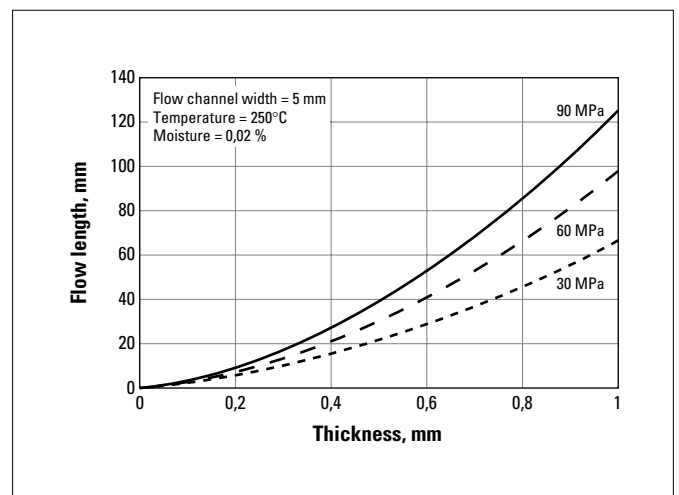

Fig. a.24 CRASTIN® T805 NC010

The information provided in this documentation corresponds to our knowledge on the subject at the date of its publication. This information may be subject to revision as new knowledge and experience becomes available. The data provided fall within the normal range of product properties and relate only to the specific material designated; these data may not be valid for such material used in combination with any other materials or additives or in any process, unless expressly indicated otherwise. The data provided should not be used to establish specification limits nor used alone as the basis of design; they are not intended to substitute for any testing you may need to conduct to determine for yourself the suitability of a specific material for your particular purposes. Since DuPont cannot anticipate all variations in actual end-use conditions DuPont makes no warranties and assumes no liability in connection with any use of this information. Nothing in this publication is to be considered as a license to operate under or a recommendation to infringe any patent rights.

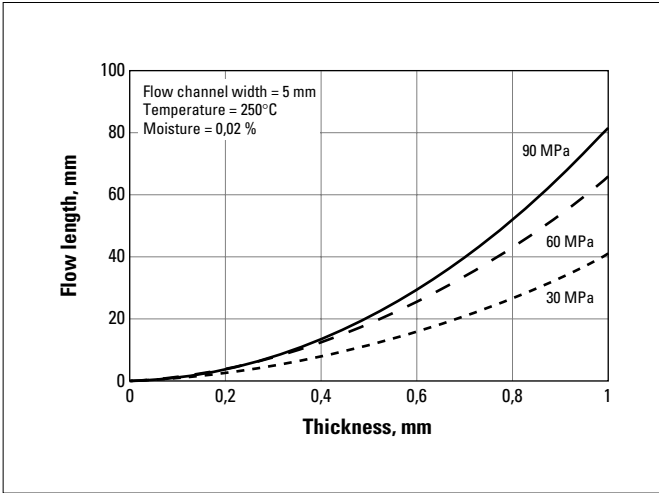

Fig. a.25 CRASTIN® SO653 NC010

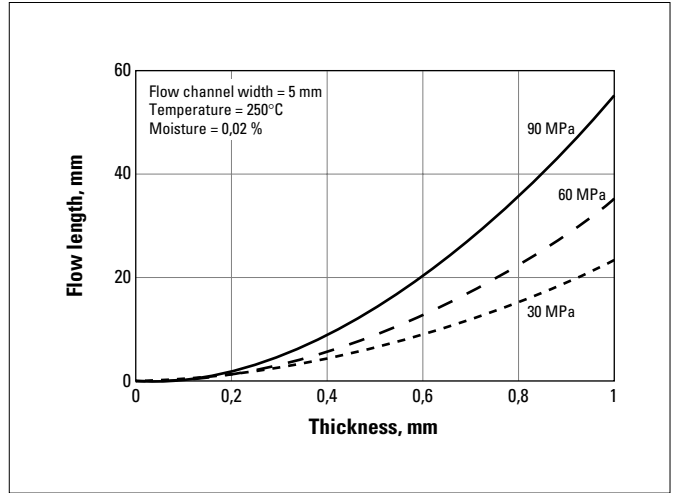

Fig. a.26 CRASTIN® SO655 NC010

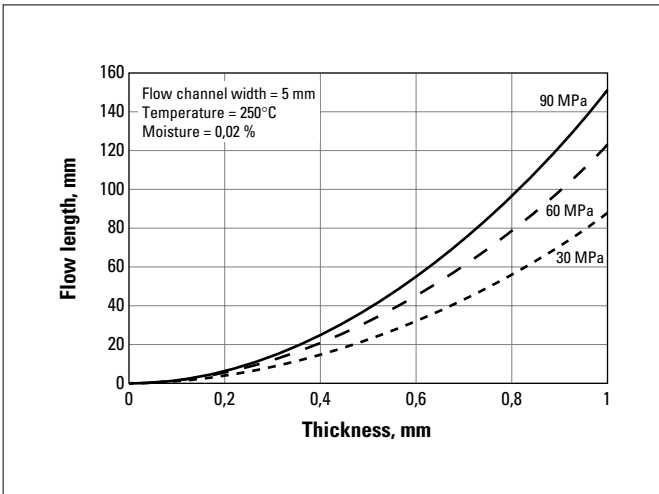

Fig. a.27 CRASTIN® CE1064 NC010

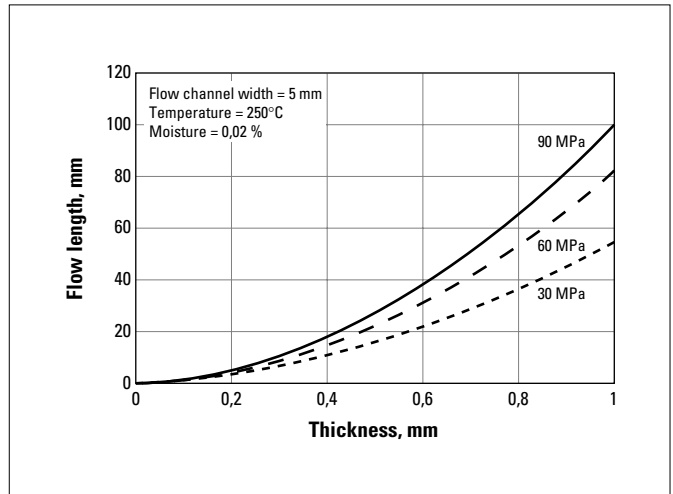

Fig. a.28 CRASTIN® S650FR NC010

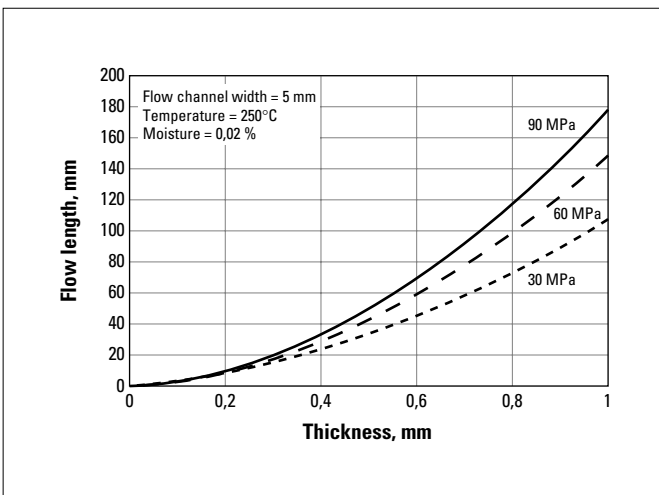

Fig. a.29 CRASTIN® S680FR YL

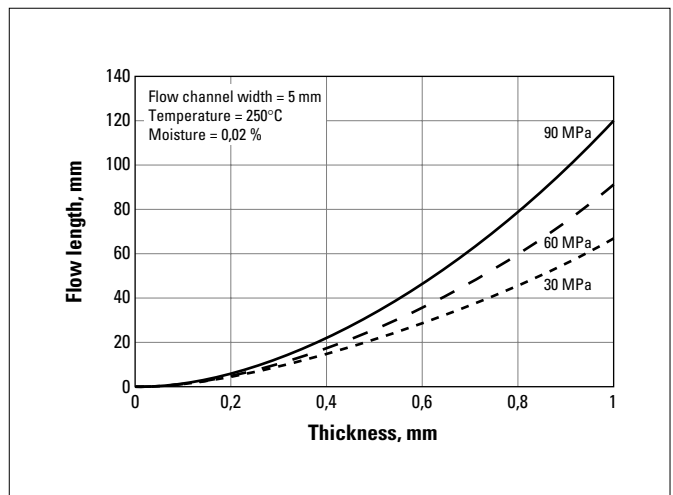

Fig. a.30 CRASTIN® T850FR NC010

The information provided in this documentation corresponds to our knowledge on the subject at the date of its publication. This information may be subject to revision as new knowledge and experience becomes available. The data provided fall within the normal range of product properties and relate only to the specific material designated; these data may not be valid for such material used in combination with any other materials or additives or in any process, unless expressly indicated otherwise. The data provided should not be used to establish specification limits nor used alone as the basis of design; they are not intended to substitute for any testing you may need to conduct to determine for yourself the suitability of a specific material for your particular purposes. Since DuPont cannot anticipate all variations in actual end-use conditions DuPont makes no warranties and assumes no liability in connection with any use of this information. Nothing in this publication is to be considered as a license to operate under or a recommendation to infringe any patent rights.

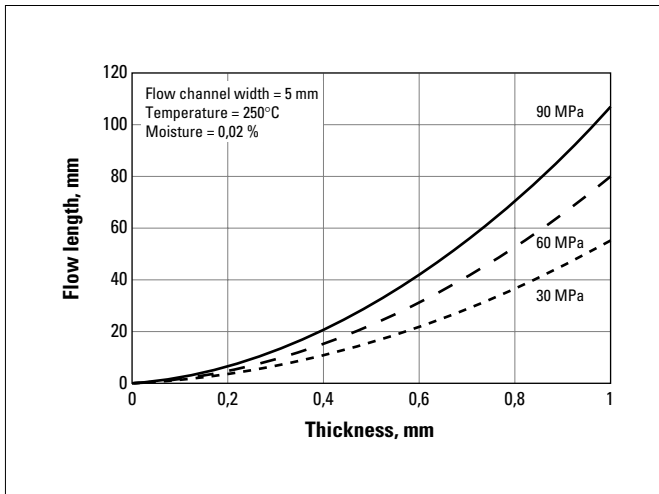

Fig. a.31 **CRASTIN® SK641FR NC010**

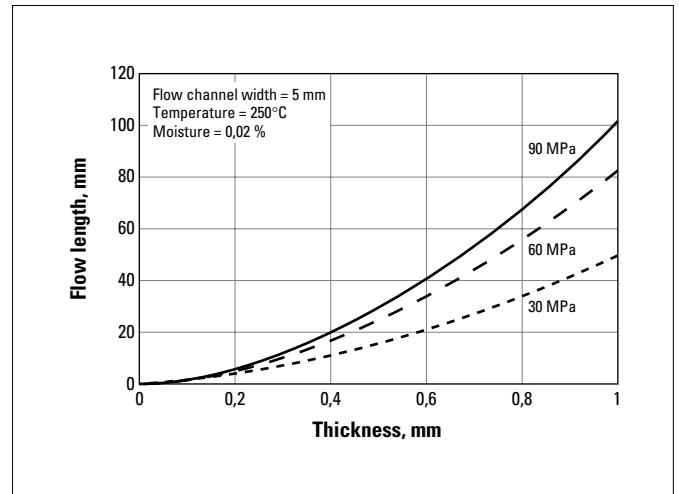

Fig. a.32 **CRASTIN® SK642FR NC010**

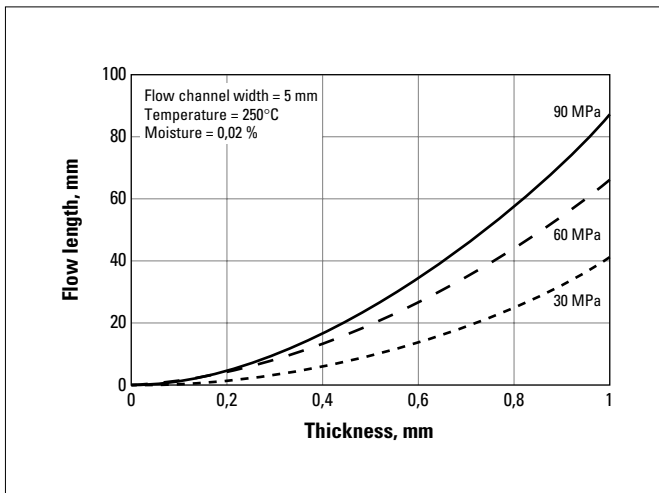

Fig. a.33 **CRASTIN® SK643FR NC010**

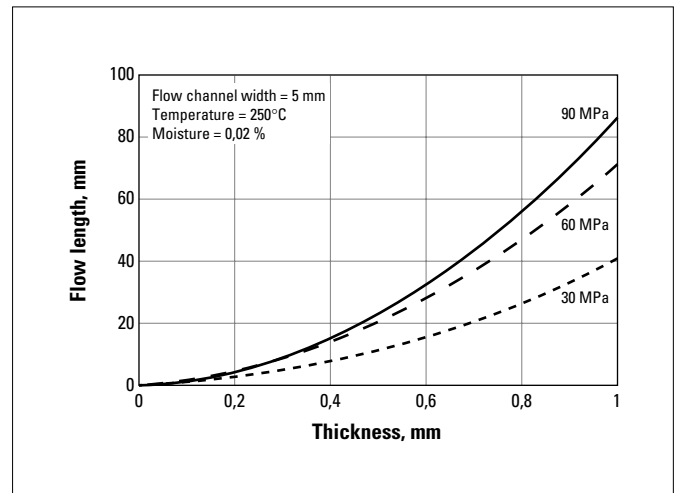

Fig. a.34 **CRASTIN® SK645FR NC010**

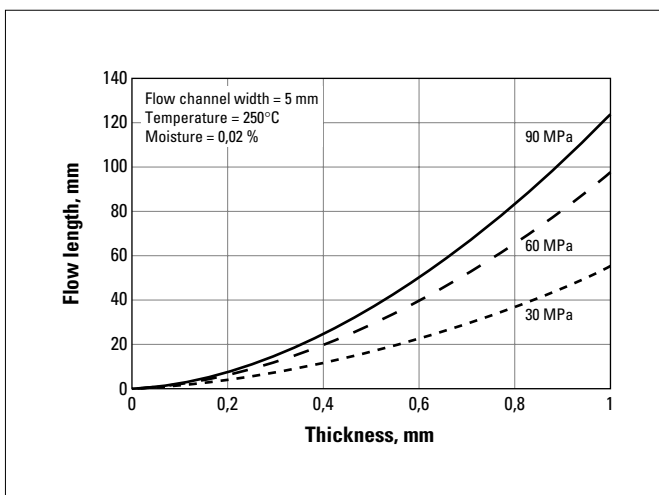

Fig. a.35 **CRASTIN® CE7910 NC010**

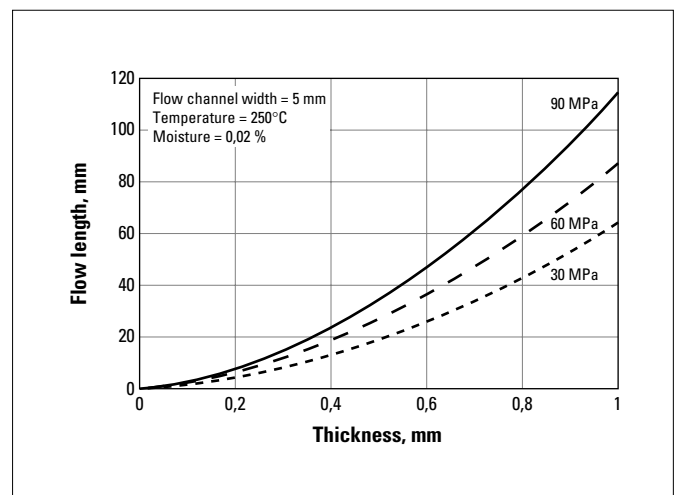

Fig. a.36 **CRASTIN® CE7931 NC010**

The information provided in this documentation corresponds to our knowledge on the subject at the date of its publication. This information may be subject to revision as new knowledge and experience becomes available. The data provided fall within the normal range of product properties and relate only to the specific material designated; these data may not be valid for such material used in combination with any other materials or additives or in any process, unless expressly indicated otherwise. The data provided should not be used to establish specification limits nor used alone as the basis of design; they are not intended to substitute for any testing you may need to conduct to determine for yourself the suitability of a specific material for your particular purposes. Since DuPont cannot anticipate all variations in actual end-use conditions DuPont makes no warranties and assumes no liability in connection with any use of this information. Nothing in this publication is to be considered as a license to operate under or a recommendation to infringe any patent rights.

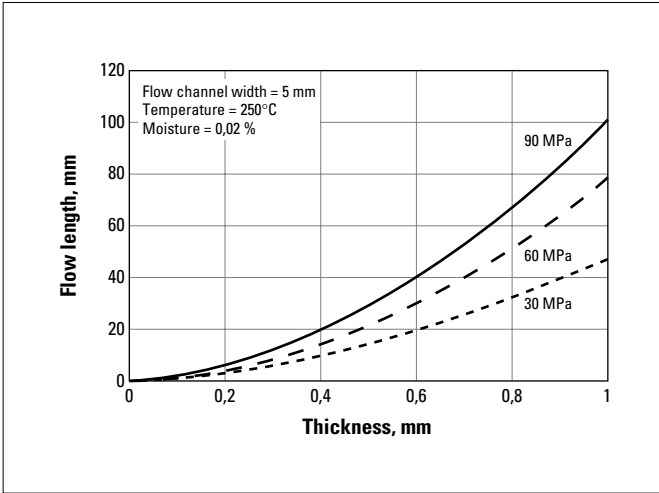

Fig. a.37 **CRASTIN® SK645FRC NC010**

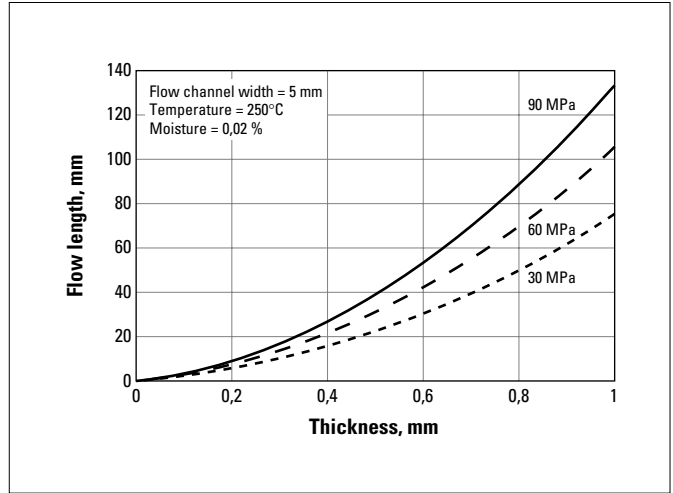

Fig. a.38 **CRASTIN® SK673GW NC010**

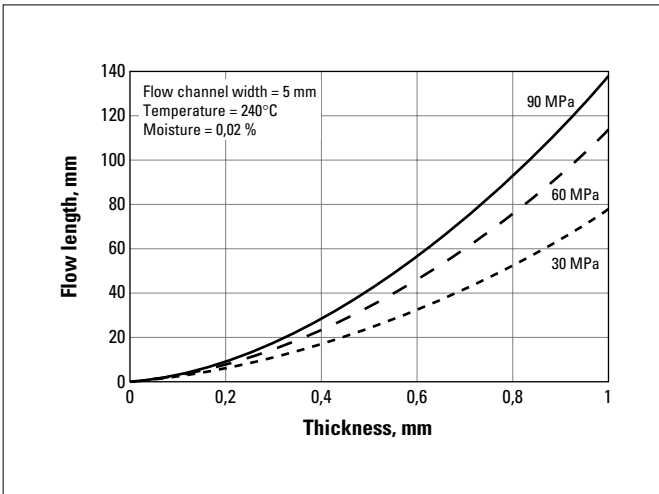

Fig. a.39 **CRASTIN® T841FR NC010**

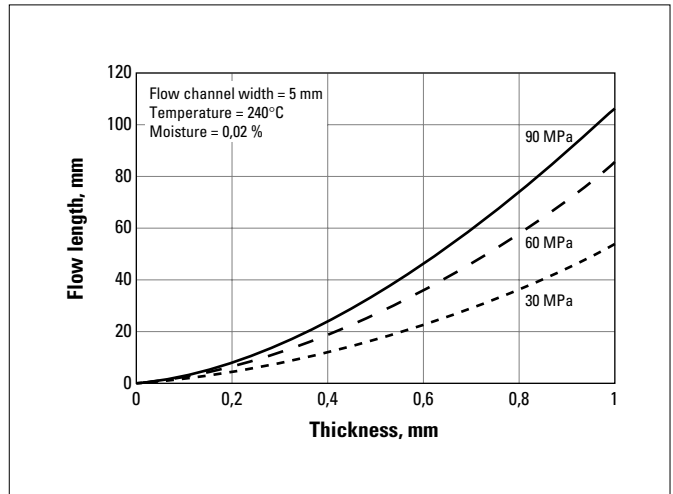

Fig. a.40 **CRASTIN® T843FR NC010**

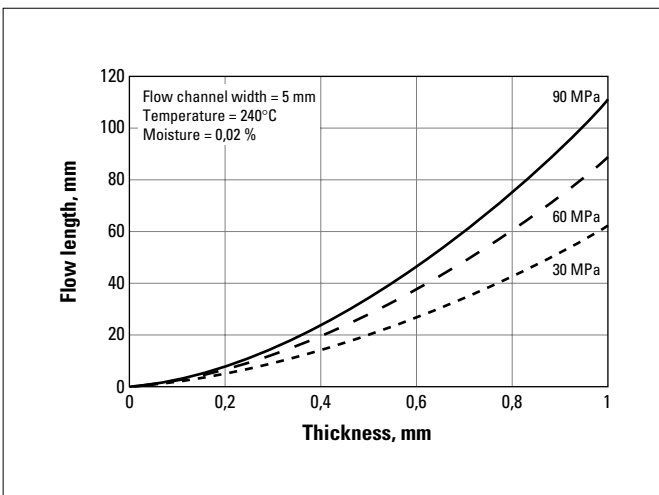

Fig. a.41 **CRASTIN® T845FR NC010**

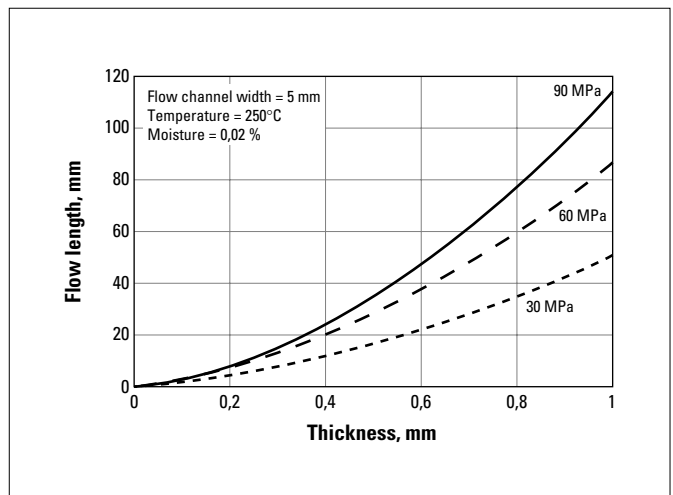

Fig. a.42 **CRASTIN® LW9020FR NC010**

The information provided in this documentation corresponds to our knowledge on the subject at the date of its publication. This information may be subject to revision as new knowledge and experience becomes available. The data provided fall within the normal range of product properties and relate only to the specific material designated; these data may not be valid for such material used in combination with any other materials or additives or in any process, unless expressly indicated otherwise. The data provided should not be used to establish specification limits nor used alone as the basis of design; they are not intended to substitute for any testing you may need to conduct to determine for yourself the suitability of a specific material for your particular purposes. Since DuPont cannot anticipate all variations in actual end-use conditions DuPont makes no warranties and assumes no liability in connection with any use of this information. Nothing in this publication is to be considered as a license to operate under or a recommendation to infringe any patent rights.

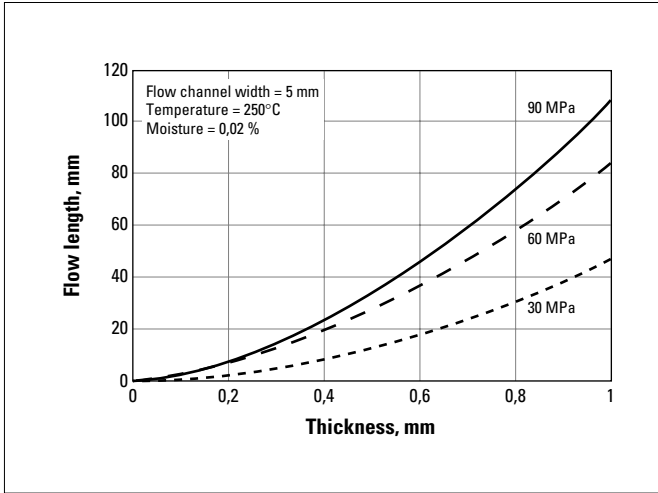

Fig. a.43 **CRASTIN® LW9030FR NC010**

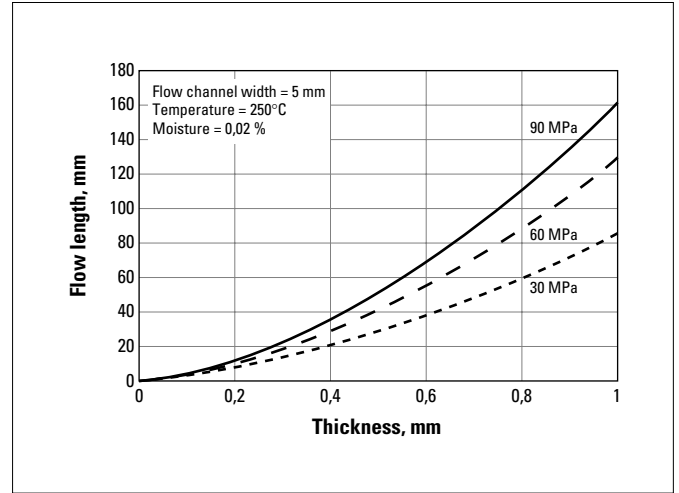

Fig. a.44 **CRASTIN® LW9320FR NC010**

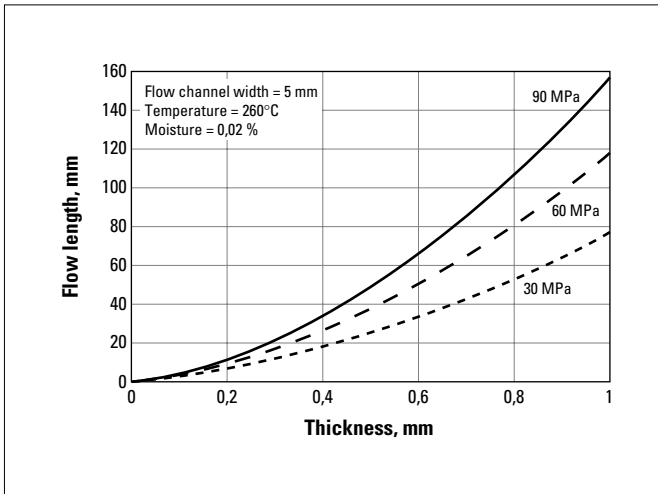

Fig. a.45 **CRASTIN® LW9330FR NC010**

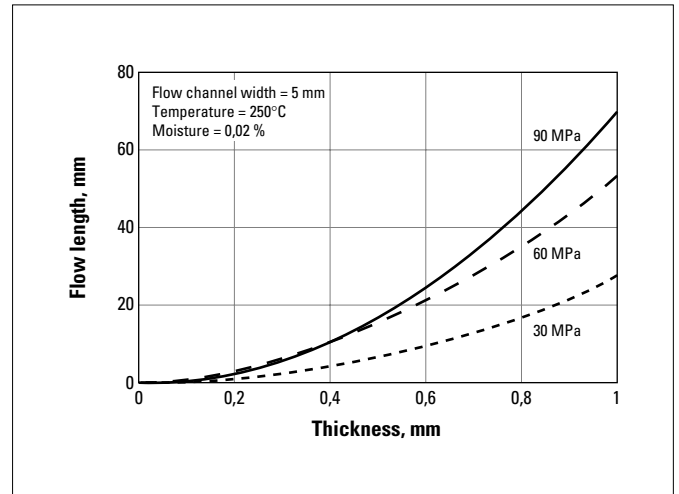

Fig. a.46 **CRASTIN® HTI619 NC010**

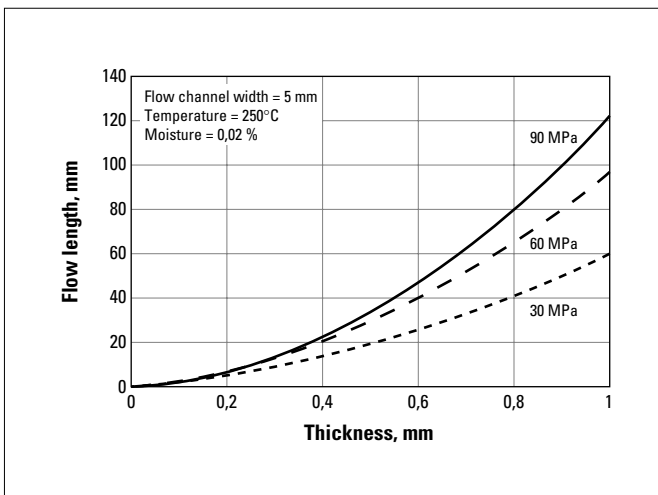

Fig. a.47 **CRASTIN® HTI668FR NC010**

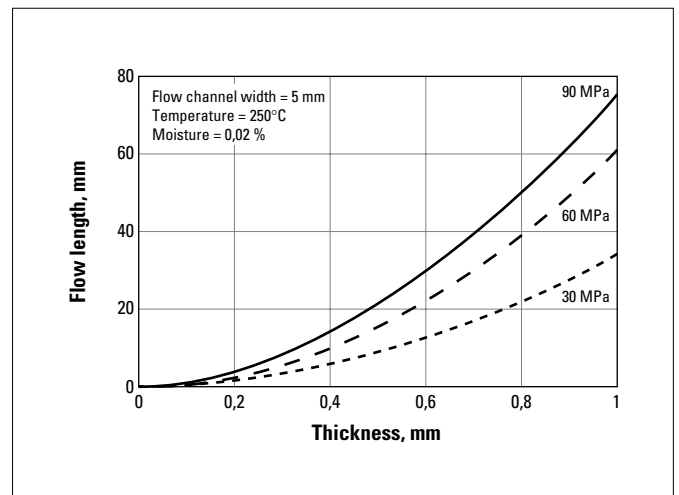

Fig. a.48 **CRASTIN® HTI681FR YL**

The information provided in this documentation corresponds to our knowledge on the subject at the date of its publication. This information may be subject to revision as new knowledge and experience becomes available. The data provided fall within the normal range of product properties and relate only to the specific material designated; these data may not be valid for such material used in combination with any other materials or additives or in any process, unless expressly indicated otherwise. The data provided should not be used to establish specification limits nor used alone as the basis of design; they are not intended to substitute for any testing you may need to conduct to determine for yourself the suitability of a specific material for your particular purposes. Since DuPont cannot anticipate all variations in actual end-use conditions DuPont makes no warranties and assumes no liability in connection with any use of this information. Nothing in this publication is to be considered as a license to operate under or a recommendation to infringe any patent rights.

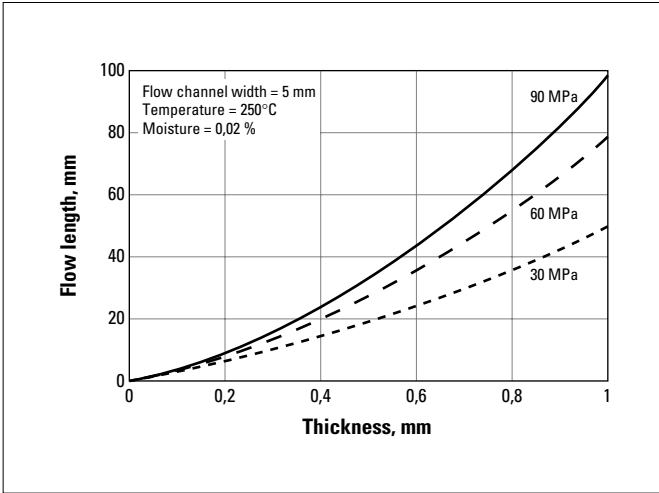

Fig. a.49 **CRASTIN® HTI688FR BK851**

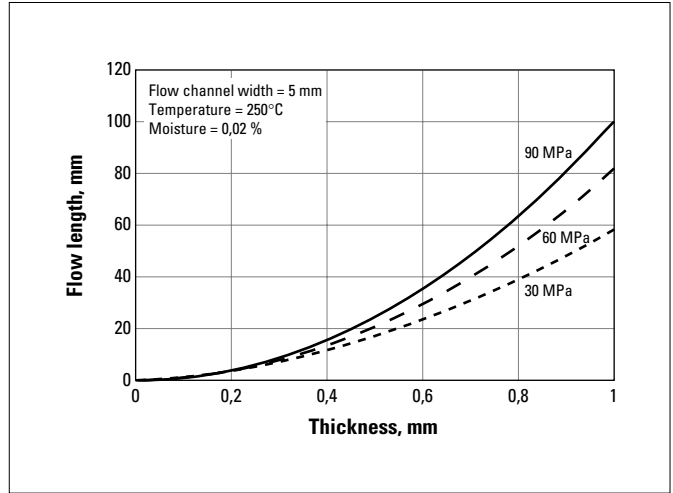

Fig. a.50 **CRASTIN® SK662FR NC010**

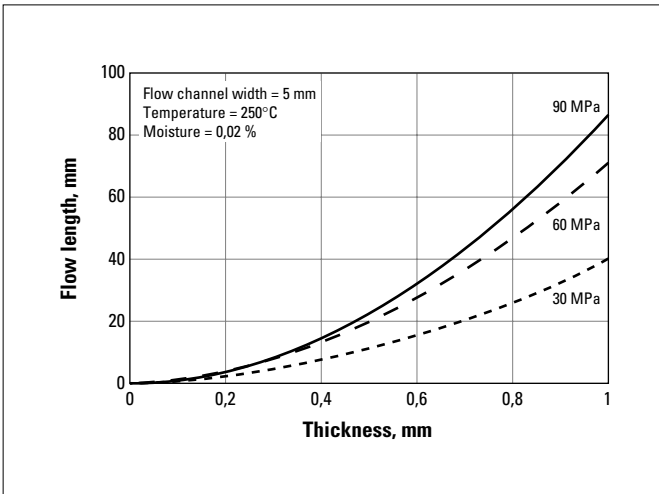

Fig. a.51 **CRASTIN® SK665FR NC010**

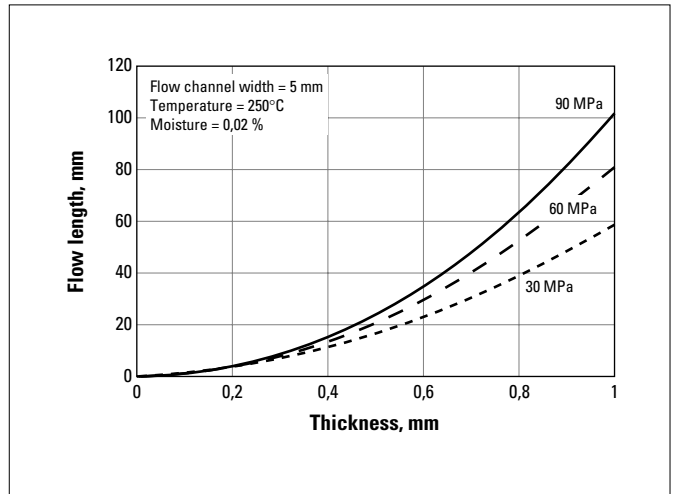

Fig. a.52 **CRASTIN® SK655FR1 NC010**

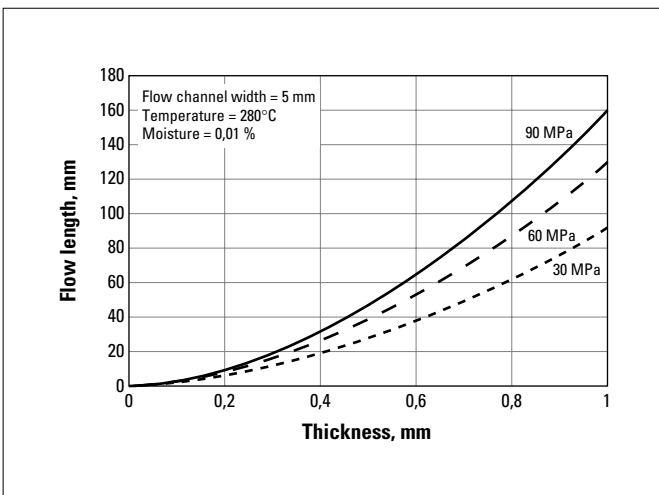

Fig. a.53 **RYNITE® 415HP NC010**

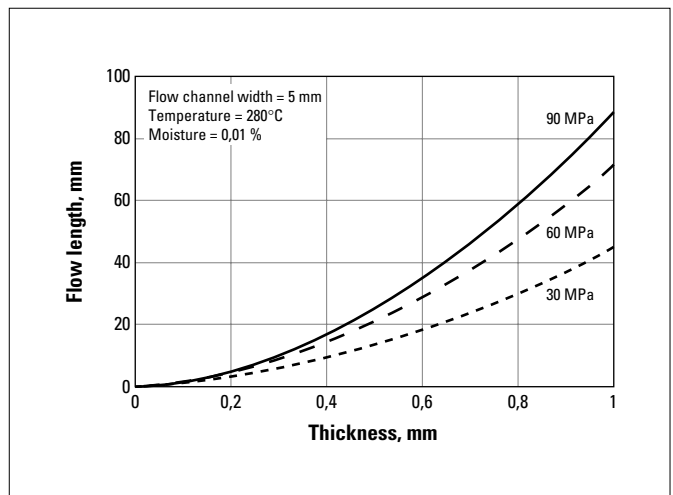

Fig. a.54 **RYNITE® 408 NC010**

The information provided in this documentation corresponds to our knowledge on the subject at the date of its publication. This information may be subject to revision as new knowledge and experience becomes available. The data provided fall within the normal range of product properties and relate only to the specific material designated; these data may not be valid for such material used in combination with any other materials or additives or in any process, unless expressly indicated otherwise. The data provided should not be used to establish specification limits nor used alone as the basis of design; they are not intended to substitute for any testing you may need to conduct to determine for yourself the suitability of a specific material for your particular purposes. Since DuPont cannot anticipate all variations in actual end-use conditions DuPont makes no warranties and assumes no liability in connection with any use of this information. Nothing in this publication is to be considered as a license to operate under or a recommendation to infringe any patent rights.

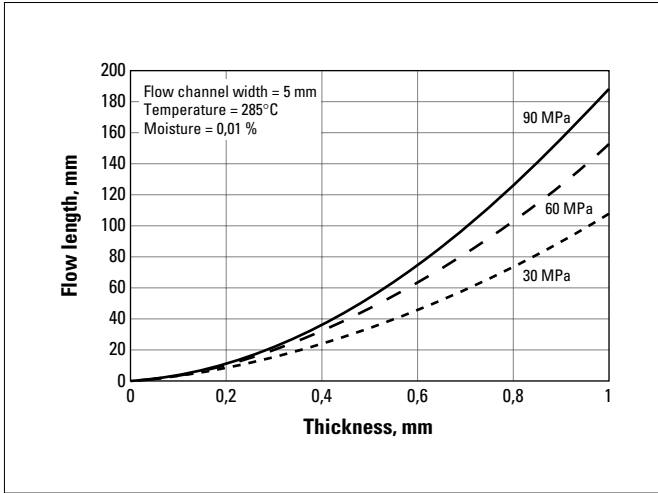

Fig. a.55 RYNITE® 520 NC010

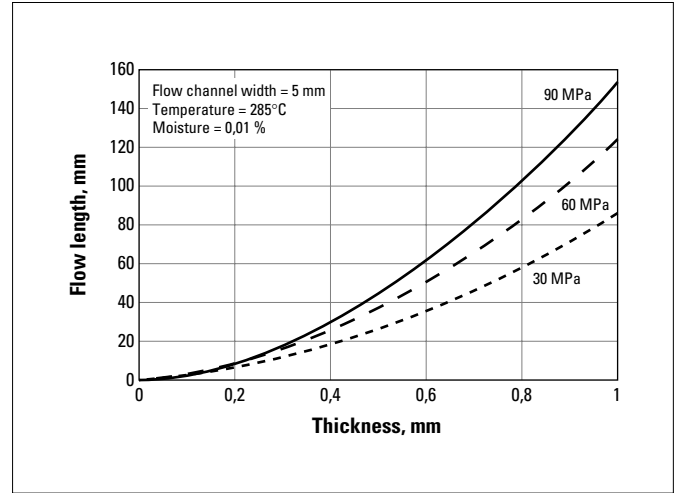

Fig. a.56 RYNITE® 530 NC010

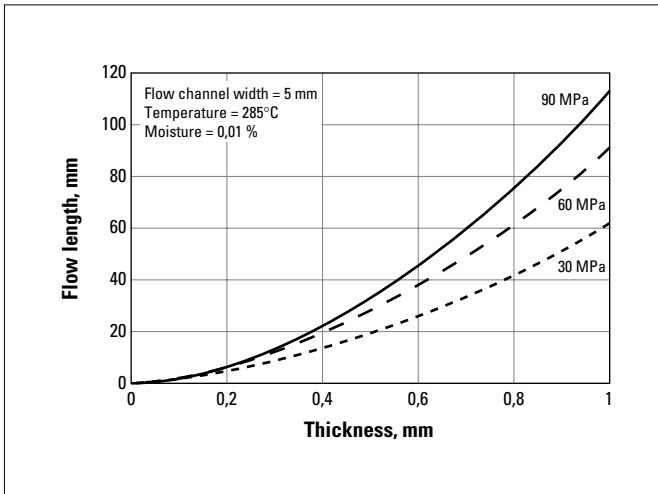

Fig. a.57 RYNITE® 545 NC010

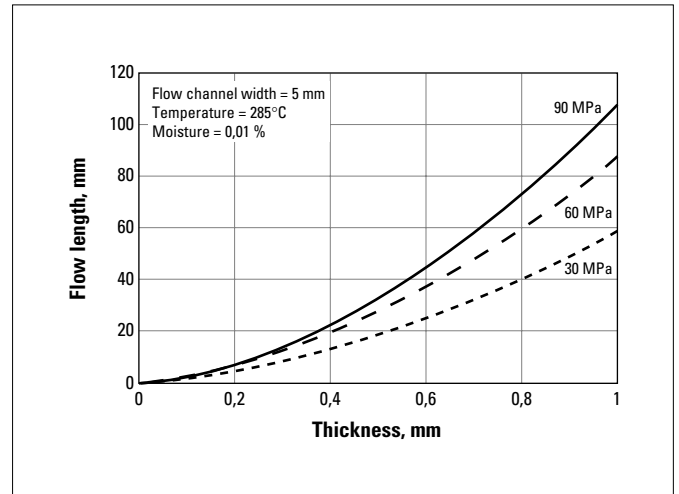

Fig. a.58 RYNITE® 555 NC010

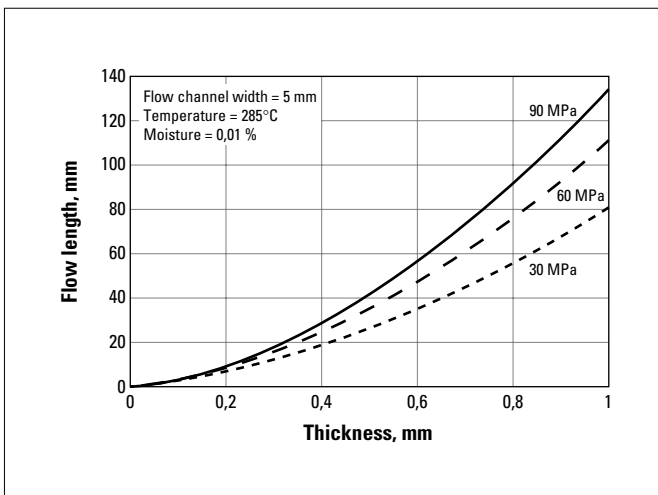

Fig. a.59 RYNITE® 935 NC010

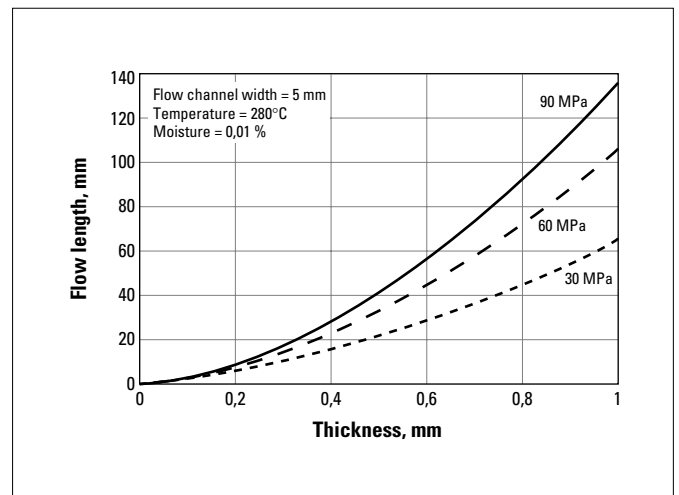

Fig. a.60 RYNITE® 940 BK505

The information provided in this documentation corresponds to our knowledge on the subject at the date of its publication. This information may be subject to revision as new knowledge and experience becomes available. The data provided fall within the normal range of product properties and relate only to the specific material designated; these data may not be valid for such material used in combination with any other materials or additives or in any process, unless expressly indicated otherwise. The data provided should not be used to establish specification limits nor used alone as the basis of design; they are not intended to substitute for any testing you may need to conduct to determine for yourself the suitability of a specific material for your particular purposes. Since DuPont cannot anticipate all variations in actual end-use conditions DuPont makes no warranties and assumes no liability in connection with any use of this information. Nothing in this publication is to be considered as a license to operate under or a recommendation to infringe any patent rights.

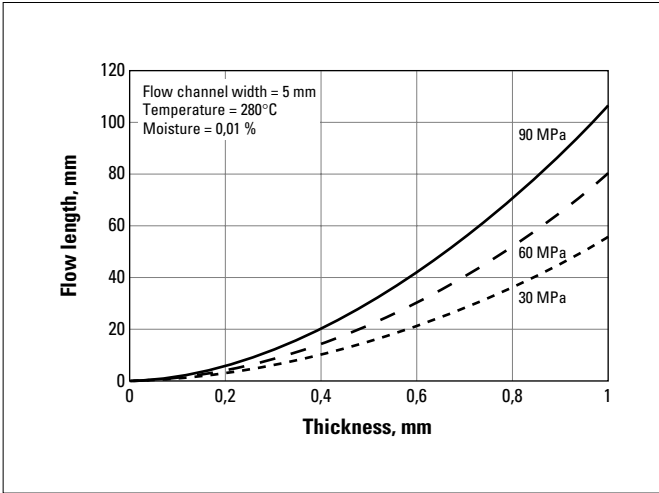

Fig. a.61 RYNITE® 530CS NC010

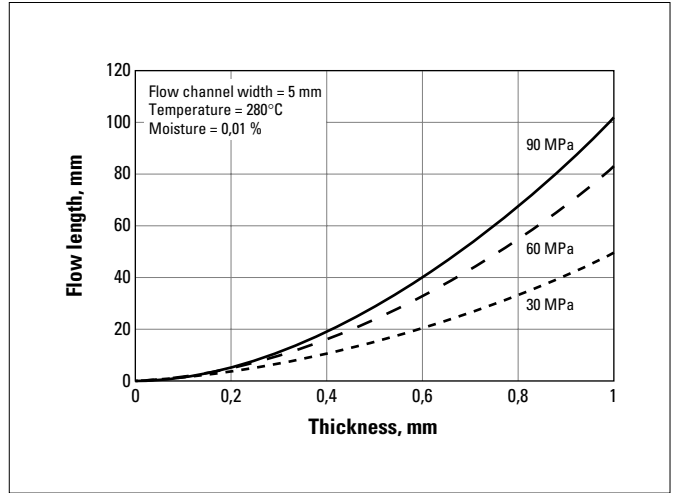

Fig. a.62 RYNITE® 936CS NC010

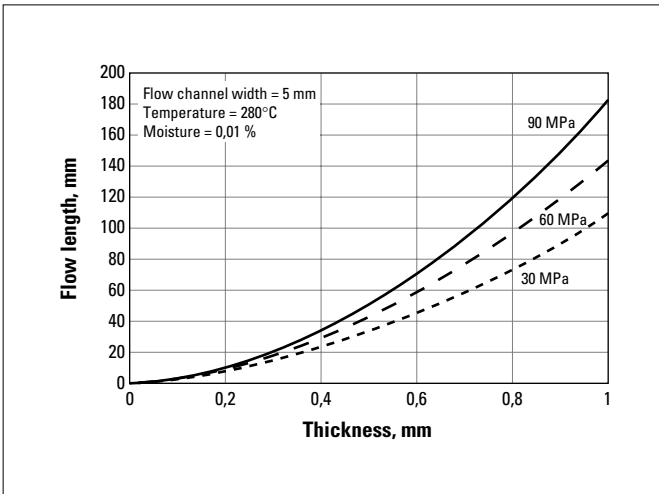

Fig. a.63 RYNITE® FR515 NC010

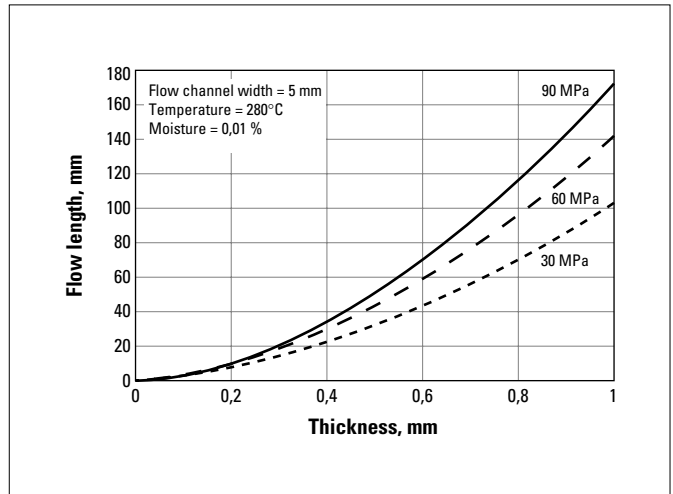

Fig. a.64 RYNITE® FR530L NC010

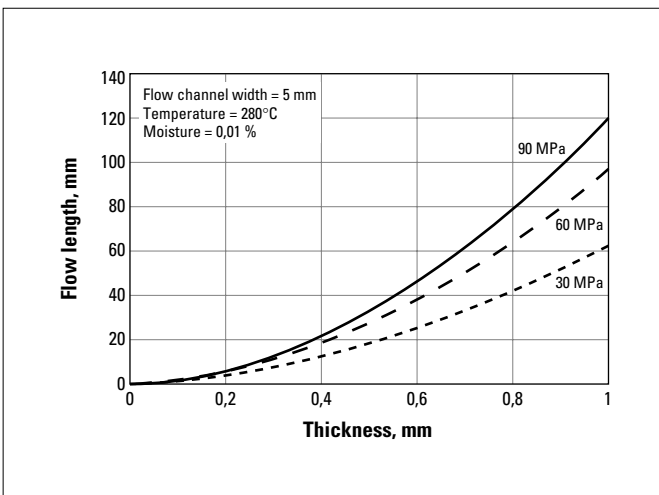

Fig. a.65 RYNITE® FR543 NC010

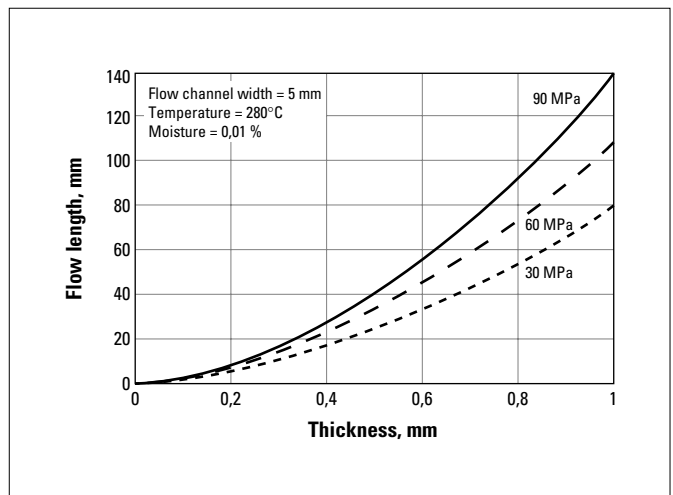

Fig. a.66 RYNITE® FR943 NC010

The information provided in this documentation corresponds to our knowledge on the subject at the date of its publication. This information may be subject to revision as new knowledge and experience becomes available. The data provided fall within the normal range of product properties and relate only to the specific material designated; these data may not be valid for such material used in combination with any other materials or additives or in any process, unless expressly indicated otherwise. The data provided should not be used to establish specification limits nor used alone as the basis of design; they are not intended to substitute for any testing you may need to conduct to determine for yourself the suitability of a specific material for your particular purposes. Since DuPont cannot anticipate all variations in actual end-use conditions DuPont makes no warranties and assumes no liability in connection with any use of this information. Nothing in this publication is to be considered as a license to operate under or a recommendation to infringe any patent rights.

For further information on Engineering Polymers contact:

Belgique/België

Du Pont de Nemours (Belgium)
Antoon Spinoystraat 6
B-2800 Mechelen
Tel. (15) 44 14 11
Telex 22 554
Telefax (15) 44 14 09

Bulgaria

Du Pont Bulgaria
18, Tcherni Vrah Blvd.
Bldg. 2, Floor 5
BG-1407 Sofia
Tel. (2) 66 59 13/66 57 36
Telex 24 261 DUPONT BG
Telefax (2) 65 63 29/66 56 11

Česká Republika a Slovenská Republika

Du Pont CZ, s.r.o.
Pekarska 14/268
CZ-15500 Praha 5 – Jinonice
Tel. +420-2-57 41 41 11
Telefax +420-2-57 41 41 50-51

Danmark

DuPont Danmark A/S
Roskildevej 163
Post Boks 139
DK-2620 Albertslund
Tel. +45 43 62 36 00
Telefax +45 43 62 36 17

Deutschland

Du Pont de Nemours
(Deutschland) GmbH
DuPont Straße 1
D-61343 Bad Homburg
Tel. (06172) 87 0
Telex 410 676 DPD D
Telefax (06172) 87 27 01

Egypt

Medgenco International Trade Co.
13, El Bostan Street
ET-Cairo
Tel. (02) 392 78 66
Telex 93 742 MK UN
Telefax (02) 392 84 87

España

Du Pont Ibérica S.A.
Edificio L'IIlla
Avda. Diagonal 561
E-08029 Barcelona
Tel. (3) 227 60 00
Telefax (3) 227 62 00

France

Du Pont de Nemours (France) S.A.
137, rue de l'Université
F-75334 Paris Cedex 07
Tel. 01 45 50 65 50
Telex 206 772 dupon
Telefax 01 47 53 09 67

Hellas

Du Pont Agro Hellas S.A.
12, Solomou & Vas. Georgiou Street
GR-152 32 Halandri, Athina
Tel. (01) 680 16 14
Telefax (01) 680 16 11

Israël

Gadot
Chemical Terminals (1985) Ltd.
22, Shalom Aleichem Street
IL-633 43 Tel Aviv
Tel. (3) 528 62 62
Telex 33 744 GADOT IL
Telefax (3) 282 717

Italia

Du Pont de Nemours Italiana S.p.A.
Via Aosta 8
I-20063 Cernusco sul Naviglio (Mi)
Tel. (02) 25 302.1
Telefax (02) 92 107 845

Magyarország

Serviced by Interowa.
See under Österreich.

Maroc

Deborel Maroc S. A.
40, boulevard d'Anfa - 10°
MA-Casablanca
Tel. (2) 27 48 75
Telex 23 719 BOUKBEN
Telefax (2) 26 54 34

Norge

Distrupol Nordic
Niels Leuchsvei 99
N-1343 Eiksmarka
Tel. 67 14 10 00
Telefax 67 14 02 20

Österreich

Interowa
Führer-Haimendorf KG
Bräuhausgasse 3-5
A-1050 Wien
Tel. (01) 512 35 71
Telex 112 993 IROWA A
Telefax (01) 512 35 71 12/
512 35 71 31

Polska

Du Pont Conoco Poland Sp.z o.o.
ul. Prosta 69
PL-00-838 Warszawa
Tel. (22) 635 04 01
Telefax (22) 691 09 00

Portugal

ACENYL
Rua do Campo Alegre, 672 - 1°
P-4100 Porto
Tel. (2) 69 24 25/69 26 64
Telex 23 136 MACOL
Telefax (2) 600 02 07

Romania

Serviced by Interowa.
See under Österreich.

Russia

E. I. du Pont de Nemours & Co. Inc.
Representative Office
B. Palashevsky Pereulok 13/2
SU-103 104 Moskva
Tel. (095) 797 22 00
Telex 413 778 DUMOS SU
Telefax (095) 797 22 01

Schweiz/Suisse/Svizzera

Dolder AG
Immengasse 9
Postfach 14695
CH-4004 Basel
Tel. (061) 326 66 00
Telex 962 306 DOL CH
Telefax (061) 326 62 04

Slovenija

Serviced by Interowa.
See under Österreich.

Suomi/Finland

Du Pont Suomi Oy
Piispankalliontie 17
PO Box 199
FIN-02201 Espoo
Tel. +358-9-7256 6100
Telefax +358-9-7256 6166

Sverige

DuPont Sverige AB
Box 23
S-164 93 Kista (Stockholm)
Tel. +46 8-750 40 20
Telefax +46 8-750 97 97

Türkiye

Du Pont Products S.A.
Turkish Branch Office
Sakir Kesebir cad. Plaza 4
No 36/7, Balmumcu
TR-80700 Istanbul
Tel. (212) 275 33 83
Telex 26541 DPIS TR
Telefax (212) 211 66 38

Ukraine

Du Pont de Nemours
International S.A.
Representative Office
3, Glazunova Street
Kyiv 252042
Tel. (044) 294 9633/269 1302
Telefax (044) 269 1181

United Kingdom

Du Pont (U.K.) Limited
Maylands Avenue
GB-Hemel Hempstead
Herts. HP2 7DP
Tel. (01442) 34 65 00
Telefax (01442) 24 94 63

Argentina

Du Pont Argentina S.A.
Avda. Mitre y Calle 5
(1884) Berazategui-Bs.As.
Tel. (541) 319-4484/85/86
Telefax (541) 319-4417

Brasil

Du Pont do Brasil S.A.
Al. Itapecuru, 506 Alphaville
06454-080 Barueri-São Paulo
Tel. (5511) 421-8468/8556

Asia Pacific

Du Pont Kabushiki Kaisha
Arco Tower, 14th Fl.
8-1, Shimomeguro 1-chome
Meguro-ku, Tokyo 153
Tel. (03) 5424 6100

South Africa

Plastamid (Pty) Ltd.
43 Coleman Street
P.O. Box 59
Elsies River 7480
Cape Town
Tel. 27 (21) 592 12 00
Telefax 27 (21) 592 14 09

USA

DuPont Engineering Polymers
Barley Mill Plaza, Building #22
P.O. Box 80022
Wilmington, Delaware 19880
Tel. (302) 892 0541
Telefax (302) 892 0737

Requests for further information
from countries not listed above
should be sent to:

Du Pont de Nemours International S.A.

2, chemin du Pavillon
CH-1218 Le Grand-Saconnex
Geneva
Tel. (022) 717 51 11
Telex 415 777 DUP CH
Telefax (022) 717 52 00

Internet location:

<http://www.dupont.com/enggpolymerseurope>

The information provided in this documentation corresponds to our knowledge on the subject at the date of its publication. This information may be subject to revision as new knowledge and experience becomes available. The data provided fall within the normal range of product properties and relate only to the specific material designated; these data may not be valid for such material used in combination with any other materials or additives or in any process, unless expressly indicated otherwise. The data provided should not be used to establish specification limits nor used alone as the basis of design; they are not intended to substitute for any testing you may need to conduct to determine for yourself the suitability of a specific material for your particular purposes. Since DuPont cannot anticipate all variations in actual end-use conditions DuPont makes no warranties and assumes no liability in connection with any use of this information. Nothing in this publication is to be considered as a license to operate under or a recommendation to infringe any patent rights.

Caution: Do not use this product in medical applications involving permanent implantation in the human body. For other medical applications see "DuPont Medical Caution Statement", H-50102.

Start
with DuPont
Engineering Polymers



Injection moulding recommendations for CRASTIN® and RYNITE® (table continues on page 36)

Description	Denomination	Drying temperature °C	Drying time h	Melt temperature optimum °C	Melt temperature range °C	Mould temperature optimum °C	Mould temperature range °C	Moulding shrinkage ISO 294-4 (2 × 60 × 60 mm)				
								Annealed				
								⊥	∥	⊥	∥	
								%	%	%	%	
CRASTIN 6129	extrusion grade	PBT	110-130	2-4	250	240-260	80	30-130	1,5	1,7	2,1	2
CRASTIN 6130	extrusion grade	PBT	110-130	2-4	250	240-260	80	30-130	1,45	1,6	2,05	1,95
CRASTIN CE1064	flame retarded, easy flow	PBT	110-130	2-4	250	240-260	80	30-130	1,85	2	2,25	2,45
CRASTIN CE7030		PBT GF30	110-130	2-4	250	240-260	80	30-130	1,2	0,35	1,45	0,4
CRASTIN CE7910	flame retarded	PBT GF10	110-130	2-4	250	240-260	80	30-130	1,45	0,85	1,70	1
CRASTIN CE7931	flame retarded	PBT GF30	110-130	2-4	250	240-260	80	30-130	1,3	0,35	1,55	0,4
CRASTIN HR5015F	hydrolysis stabilized	PBT GF15	110-130	2-4	250	240-260	80	30-130	0,95	0,35	1,2	0,5
CRASTIN HR5030F	hydrolysis stabilized	PBT GF30	110-130	2-4	250	240-260	80	30-130	1	0,25	1,25	0,3
CRASTIN HTI619	high tracking	PBT (M + GF) 50	110-130	2-4	250	240-260	80	30-130	1,1	0,4	1,25	0,5
CRASTIN HTI668FR	high tracking	PBT (GF + M) 45	110-130	2-4	250	240-260	80	30-130	0,85	0,45	1,1	0,6
CRASTIN HTI681FR	high tracking, low warpage	PBT M10	110-130	2-4	250	240-260	80	30-130	1,65	2	2	2,4
CRASTIN HTI688FR	high tracking	PBT (M + GF) 45	110-130	2-4	250	240-260	80	30-130	1,00	0,30	1,2	0,35
CRASTIN LW9020	low warpage	PBT blend GF20	110-130	2-4	250	240-260	80	30-130	0,65	0,35	0,9	0,55
CRASTIN LW9020FR	flame retarded, low warpage	PBT blend GF20	110-130	2-4	250	240-260	80	30-130	0,75	0,4	1	0,55
CRASTIN LW9030	low warpage	PBT blend GF30	110-130	2-4	250	240-260	80	30-130	0,65	0,25	0,95	0,4
CRASTIN LW9030FR	flame retarded, low warpage	PBT blend GF30	110-130	2-4	250	240-260	80	30-130	0,75	0,3	1	0,4
CRASTIN LW9130	low warpage	PBT GF30	110-130	2-4	250	240-260	80	30-130	0,65	0,25	1	0,4
CRASTIN LW9236	high gloss, low warpage	PBT blend (G-flake + GF) 36	110-130	2-4	260	260-270	90	80-100	0,55	0,35	0,75	0,5
CRASTIN LW9320	low warpage	PBT blend GF20	110-130	2-4	260	240-260	100	30-130	0,65	0,4	0,85	0,5
CRASTIN LW9320FR	flame retarded, low warpage	PBT blend GF20	110-130	2-4	260	240-260	100	65-130	0,75	0,45	0,95	0,5
CRASTIN LW9330	low warpage	PBT blend GF30	110-130	2-4	260	240-260	100	30-130	0,6	0,25	0,85	0,4
CRASTIN LW9330FR	flame retarded, low warpage	PBT blend GF30	110-130	2-4	260	240-260	100	65-130	0,6	0,2	0,9	0,3
CRASTIN S600F10	high viscous	PBT	110-130	2-4	250	240-260	80	30-130	1,6	1,7	2,1	2
CRASTIN S600F20	easy flow	PBT	110-130	2-4	250	240-260	80	30-130	1,55	1,7	2,1	2
CRASTIN S620F20	fast cycling	PBT	110-130	2-4	250	240-260	80	30-130	1,8	1,9	2,3	2,4
CRASTIN S650FR	flame retarded	PBT	110-130	2-4	250	240-260	80	30-130	1,6	1,8	2,15	2,25
CRASTIN S680FR	flame retarded, very easy flow	PBT	110-130	2-4	250	240-260	80	30-130	1,8	2,3	2,25	2,8
CRASTIN SK601		PBT GF10	110-130	2-4	250	240-260	80	30-130	1,15	0,65	1,45	0,8
CRASTIN SK602		PBT GF15	110-130	2-4	250	240-260	80	30-130	1,1	0,4	1,4	0,55
CRASTIN SK603		PBT GF20	110-130	2-4	250	240-260	80	30-130	1,05	0,35	1,35	0,5
CRASTIN SK605		PBT GF30	110-130	2-4	250	240-260	80	30-130	1,1	0,3	1,35	0,4
CRASTIN SK608		PBT GF45	110-130	2-4	260	250-270	80	30-130	1,25	0,3	1,45	0,4
CRASTIN SK609		PBT GF50	110-130	2-4	260	250-270	80	30-130	1,1	0,25	1,25	0,35
CRASTIN SK641FR	flame retarded	PBT GF10	110-130	2-4	250	240-260	80	30-130	1,3	0,8	1,6	0,95
CRASTIN SK642FR	flame retarded	PBT GF15	110-130	2-4	250	240-260	80	30-130	1,25	0,65	1,5	0,75
CRASTIN SK643FR	flame retarded	PBT GF20	110-130	2-4	250	240-260	80	30-130	1,25	0,5	1,45	0,6

The information provided in this documentation corresponds to our knowledge on the subject at the date of its publication. This information may be subject to revision as new knowledge and experience becomes available. The data provided fall within the normal range of product properties and relate only to the specific material designated; these data may not be valid for such material used in combination with any other materials or additives or in any process, unless expressly indicated otherwise. The data provided should not be used to establish specification limits nor used alone as the basis of design; they are not intended to substitute for any testing you may need to conduct to determine for yourself the suitability of a specific material for your particular purposes. Since DuPont cannot anticipate all variations in actual end-use conditions DuPont makes no warranties and assumes no liability in connection with any use of this information. Nothing in this publication is to be considered as a license to operate under or a recommendation to infringe any patent rights.

Injection moulding recommendations for **CRASTIN®** and **RYNITE®** (continued)

Description	Denomination	Drying temperature °C	Drying time h	Melt temperature optimum °C	Melt temperature range °C	Mould temperature optimum °C	Mould temperature range °C	Moulding shrinkage ISO 294-4 (2 × 60 × 60 mm)				
								Annealed				
								⊥		⊥		
								%	%	%	%	
CRASTIN SK645FR	flame retarded	PBT GF30	110-130	2-4	250	240-260	80	30-130	1,25	0,35	1,5	0,45
CRASTIN SK645FRC	flame retarded, easy flow	PBT GF30	110-130	2-4	250	240-260	80	30-130	1,2	0,4	1,4	0,45
CRASTIN SK673GW	Glow wire resistant type	PBT GF20	110-130	2-4	250	240-260	80	30-130	1,25	0,45	1,55	0,55
CRASTIN SK9215	high gloss	PBT blend GF15	110-130	2-4	260	260-270	90	80-100	0,85	0,35	1,25	0,55
CRASTIN SK9220	high gloss	PBT blend GF20	110-130	2-4	260	260-270	90	80-100	0,75	0,3	1,15	0,45
CRASTIN SK9230	high gloss	PBT blend GF30	110-130	2-4	260	260-270	90	80-100	0,7	0,25	1,1	0,35
CRASTIN SO653	low warpage	PBT GB20	110-130	2-4	250	240-260	80	30-130	1,55	1,8	2	2,25
CRASTIN SO655	low warpage	PBT GB20	110-130	2-4	250	240-260	80	30-130	1,55	1,85	1,9	2,3
CRASTIN ST820	impact modified	PBT	110-130	2-4	250	240-260	80	30-130	1,55	1,7	2,25	2,5
CRASTIN T801	toughened	PBT GF10	110-130	2-4	250	240-260	80	30-130	0,9	0,55	1,3	0,8
CRASTIN T803	toughened	PBT GF20	110-130	2-4	250	240-260	80	30-130	0,85	0,35	1,15	0,45
CRASTIN T805	toughened	PBT GF30	110-130	2-4	250	240-260	80	30-130	0,85	0,25	1,15	0,35
CRASTIN T841FR	flame retarded, toughened	PBT GF10	110-130	2-4	240	240-260	80	30-130	1,15	0,7	1,5	0,9
CRASTIN T843FR	flame retarded, toughened	PBT GF20	110-130	2-4	240	240-260	80	30-130	1	0,4	1,25	0,5
CRASTIN T845FR	flame retarded, toughened	PBT GF30	110-130	2-4	240	240-260	80	30-130	1	0,3	1,3	0,35
CRASTIN T850FR	flame retarded, toughened	PBT	110-130	2-4	250	240-260	80	30-130	1,8	2	2,25	2,5
RYNITE 408	toughened	PET GF30	120	4	280	270-290	110	>95	0,85	0,25	1,05	0,35
RYNITE 415HP	toughened	PET GF15	120	4	280	270-290	110	>95	0,85	0,35	1,2	0,45
RYNITE 520		PET GF20	120	4	285	280-300	110	>95	0,85	0,25	1,3	0,3
RYNITE 530CS	colour stable	PET GF30	120	4	280	270-300	140	>130	0,6	0,15	1,15	0,25
RYNITE 936CS	colour stable	PET (Glassflake + GF) 36	120	4	280	270-300	140	>130	0,4	0,2	0,7	0,3
RYNITE 530		PET GF30	120	4	285	280-300	110	>95	0,8	0,2	1,25	0,3
RYNITE 545		PET GF45	120	4	285	280-300	110	>95	0,85	0,25	1,15	0,3
RYNITE 555		PET GF55	120	4	285	280-300	110	>95	0,8	0,25	1,1	0,3
RYNITE GW525CS	flame retarded, colour stable	PET GF25	120	4	280	270-290	110	>95	0,9	0,35		
RYNITE GW515CS	flame retarded, colour stable	PET GF15	120	4	280	270-290	110	>95	0,45	0,9		
RYNITE GW520CS	flame retarded, colour stable	PET GF20	120	4	280	270-290	110	>95	0,9	0,4		
RYNITE 935	low warpage	PET (mica + GF) 35	120	4	285	280-300	110	>95	0,7	0,3	0,9	0,35
RYNITE 940	low warpage	PET (GF + mica) 40	120	4	285	280-300	110	>95	0,7	0,2	0,9	0,25
RYNITE FR515	flame retarded	PET GF15	120	4	280	270-290	110	>95	0,85	0,35	1,15	0,45
RYNITE FR530L	flame retarded	PET GF30	120	4	280	270-290	110	>95	0,9	0,25	1,1	0,25
RYNITE FR543	flame retarded	PET GF43	120	4	280	270-290	110	>95	0,75	0,2	1,05	0,25
RYNITE FR943	flame retarded, low warpage	PET (GF + Glassflake) 43	120	4	280	270-290	110	>95	0,65	0,25	0,9	0,3
RYNITE RE4047	toughened, post consumer recycled	PET GF30	120	4	280	270-290	110	>95				
RYNITE 925ST	toughened, low warp, post consumer recycled	PET (mica + GF) 25	120	4	280	270-290	110	>95	0,8	0,45		
RYNITE 536		PET GF36	120	4	290	270-300	110	>95	0,8	0,3		

The information provided in this documentation corresponds to our knowledge on the subject at the date of its publication. This information may be subject to revision as new knowledge and experience becomes available. The data provided fall within the normal range of product properties and relate only to the specific material designated; these data may not be valid for such material used in combination with any other materials or additives or in any process, unless expressly indicated otherwise. The data provided should not be used to establish specification limits nor used alone as the basis of design; they are not intended to substitute for any testing you may need to conduct to determine for yourself the suitability of a specific material for your particular purposes. Since DuPont cannot anticipate all variations in actual end-use conditions DuPont makes no warranties and assumes no liability in connection with any use of this information. Nothing in this publication is to be considered as a license to operate under or a recommendation to infringe any patent rights.